

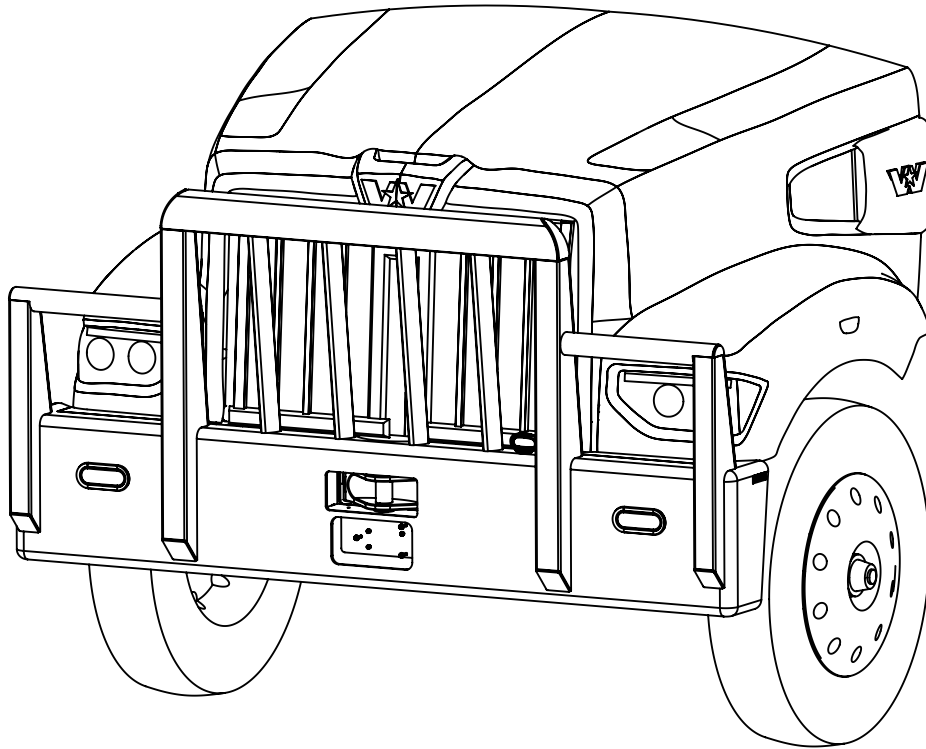

# INSTALLATION GUIDE

MODEL NUMBER: 17276

TRUCK MODEL: 2021+ WESTERN STAR 49X SET FORWARD AXLE (CENTER TOW)



## **IMPORTANT INFORMATION**

- THIS GUIDE IS ONLY APPLICABLE TO PRODUCTS AND TRUCK MODELS SPECIFIED.
- THE CORRECT SIZE AND GRADE OF HARDWARE SPECIFIED IN THIS GUIDE MUST BE USED.
- CHECK ALL MOUNTING POINTS AFTER THE FIRST 5000KM'S IN SERVICE AND PERIODICALLY THERE AFTER. RE-TORQUE IF NECESSARY.
- RECOMMENDED ADDING THREADLOCKER (LOCTITE BLUE 242) TO ALL THREADS BEFORE INSTALLING.
- ALL MAGNUM PRODUCTS MUST BE INSTALLED ACCORDING TO THIS INSTALLATION GUIDE. ANY DEVIATIONS MAY RESULT IN VOID OF WARRANTY.
- ANY ALTERATIONS TO THE PRODUCT MAY RESULT IN VOID OF WARRANTY.

## **SAFETY INFORMATION**

- PROPER PERSONAL PROTECTIVE EQUIPMENT MUST BE WORN WHEN INSTALLING THIS PRODUCT.
- SOME PARTS OF THIS PRODUCT MAY BE HEAVY OR AWKWARD TO HANDLE. USE CAUTION WHEN HANDLING.

**17276 MOOSE BUMPER**

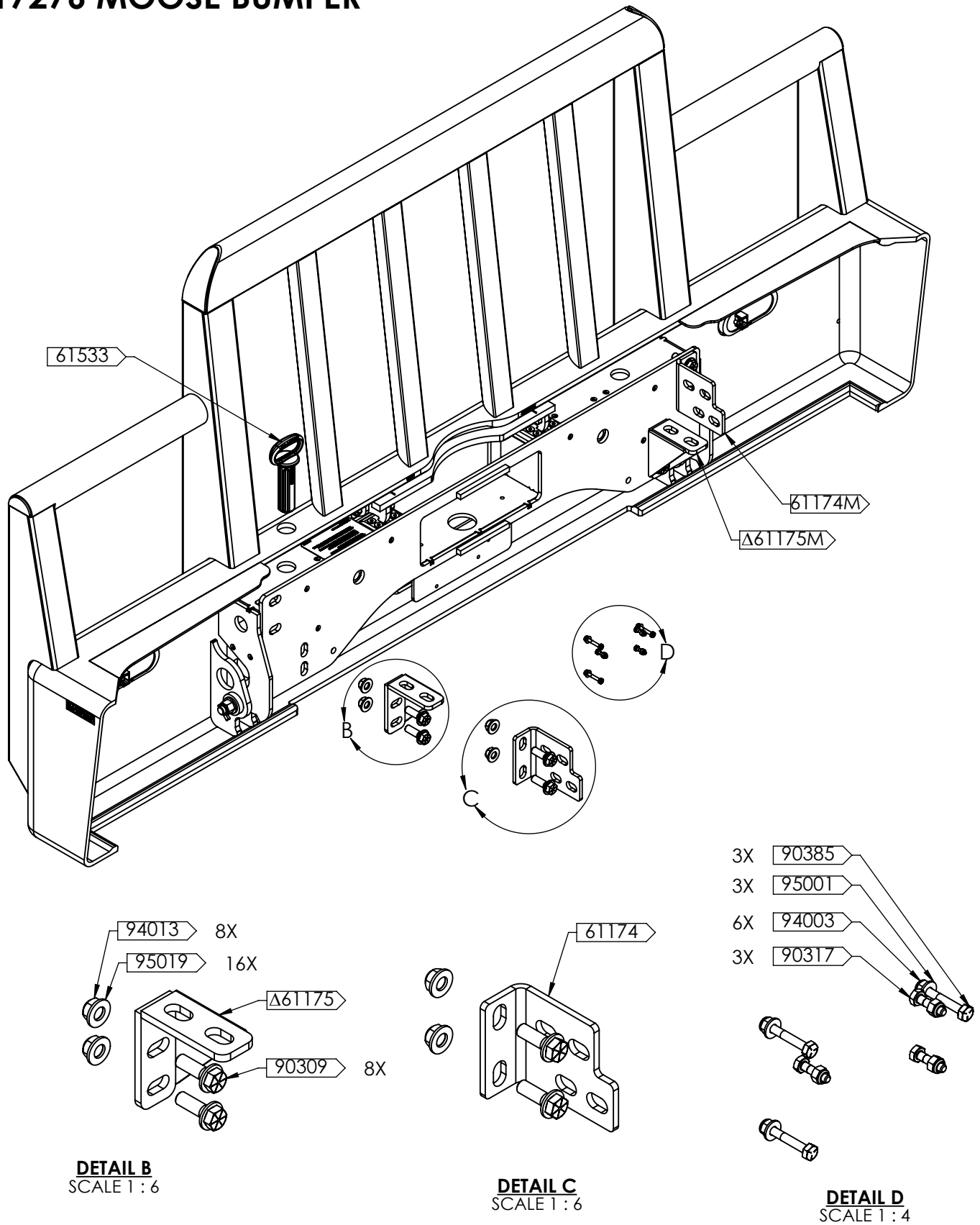

**DETAIL B**  
SCALE 1 : 6

**DETAIL C**  
SCALE 1 : 6

**DETAIL D**  
SCALE 1 : 4

\*SEE NEXT PAGE FOR LIST OF PARTS INCLUDED\*



## ASSEMBLY KIT PARTS

ITEM#	DWG	DESCRIPTION	MAT'L	DIMENSIONS	WT. EA	STOCK #	QTY.
61174	PA	MOUNT TAB	44W	SEE PA - 61174	2.8	131124	1
61174M	PA	MOUNT TAB - MIRROR	44W	SEE PA - 61174M	2.8	131125	1
61175	AA	MOUNT BRACKET WELDMENT		SEE AA - 61175	2.7	131126	1
61175M	AA	MOUNT BRACKET WELDMENT - MIRROR		SEE AA - 61175M	2.7	131127	1
61533	PA	CAST LATCH PIN	65-45-12 CAST IRON	SEE PA - 61533	3.2	131243	1
90309		HEX CAPSCREW - PLATED	GR. 8	5/8" NC X 2"	.25	101976	8
90317		HEX CAPSCREW - PLATED	GR. 5	1/4" NC X 1"	.022	101551	3
90385		HEX HEAD BOLT - PLATED	GR. 5	1/4" NC X 1 3/4"	.033	101554	3
94003		NYLOC HEX NUT - PLATED	GR. 2	1/4" NC	.0097	101459	6
94013		STOVER NUT - PLATED	GR. C	5/8" NC	.063	101481	8
95001		FLAT WASHER - PLATED	GR. 2	1/4" DIA SAE	.0043	102157	3
95019		FLAT WASHER - PLATED	GR. 8	5/8" DIA SAE	.035	102172	16

## INSTALLATION PROCEDURE

1. UNINSTALL THE TOW PIN ASSEMBLY BY REMOVING THE BOLT THAT ATTACHES IT TO THE FRAME.

2. UNINSTALL THE OEM BUMPER BY REMOVING THE FOUR BOLTS LOCATED ON THE FRONT OF THE BUMPER.

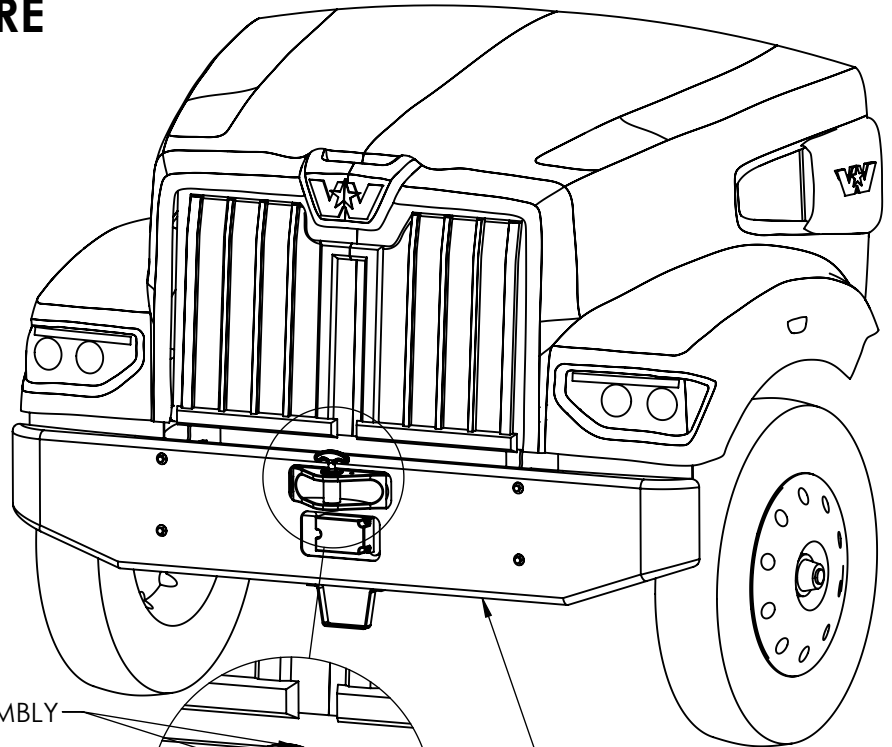

STEP 1:  
TOW PIN ASSEMBLY

STEP 2:  
OEM BUMPER

3. UNINSTALL THE PASSENGER SIDE TRUCK BRACKET AND DRIVER SIDE TRUCK BRACKET. THE HARDWARE ATTACHING THESE BRACKETS WILL BE REUSED TO INSTALL THE BUMPER.

4. REMOVE THE NUTS AND WASHERS ON THE UNDERSIDE OF THE TRUCK AS SEEN IN THE FIGURE BELOW. KEEP THIS HARDWARE FOR INSTALLATION OF THE BUMPER.

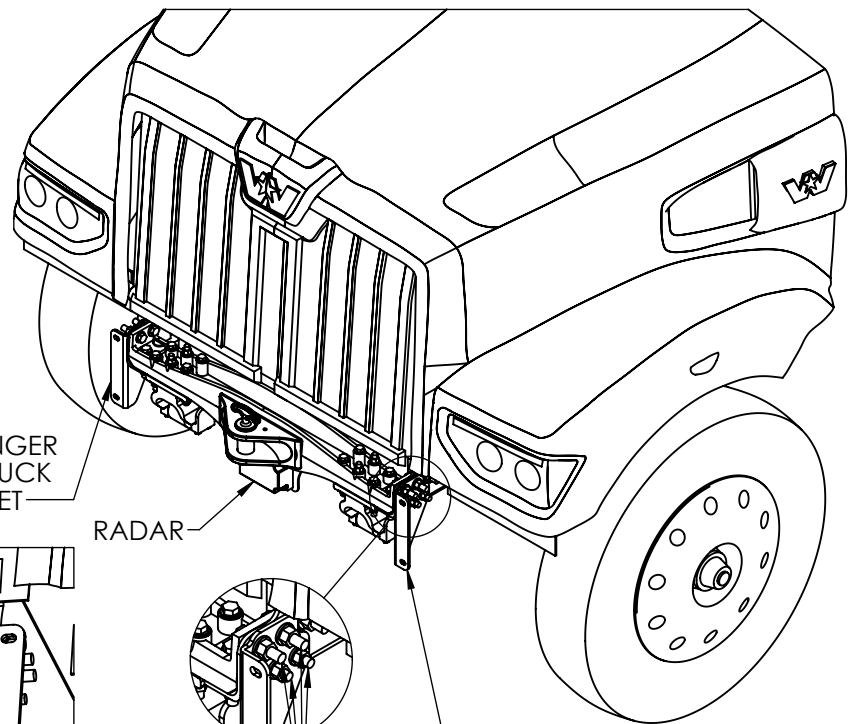

PASSENGER  
SIDE TRUCK  
BRACKET

RADAR

DRIVER SIDE  
TRUCK BRACKET

5. IF EQUIPPED, REMOVE THE RADAR COVER AND RADAR FROM THE TRUCK.

STEP 4: REMOVE  
AND KEEP  
HARDWARE

STEP 3: KEEP &  
RE-USE  
HARDWARE



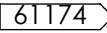
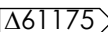
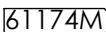
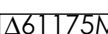

## INSTALLATION PROCEDURE

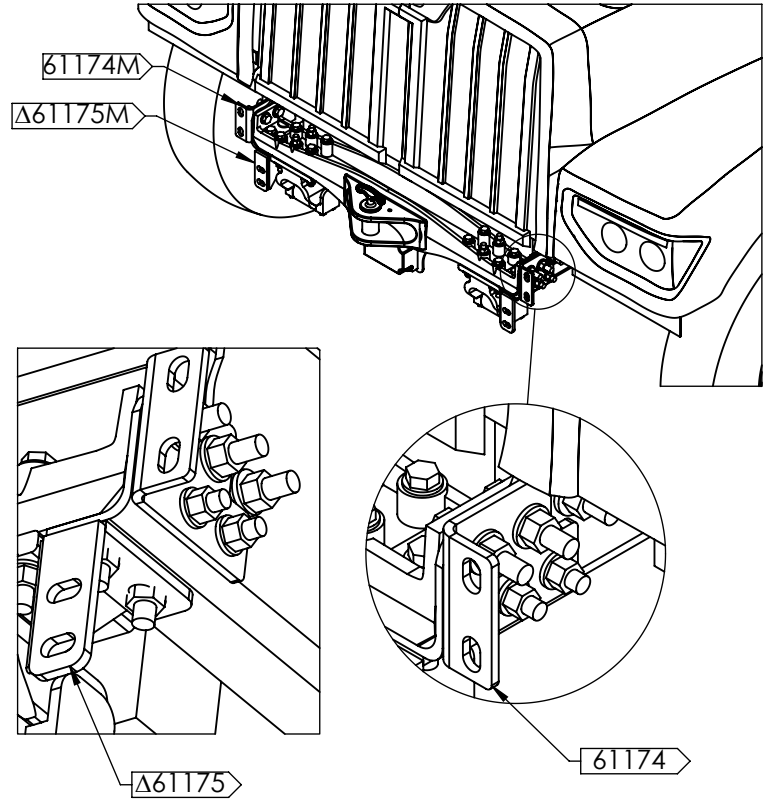
6. INSTALL THE SUPPLIED MOUNT BRACKETS  &  ON THE DRIVER SIDE. INSTALL  &  ON THE PASSENGER SIDE. SECURE THEM USING THE ORIGINAL HARDWARE.

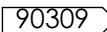

7. ATTACH THE BUMPER TO THE MOUNT BRACKETS USING THE SUPPLIED HARDWARE:

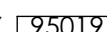
- 8 X  BOLTS
- 8 X  NUTS
- 16 X  WASHERS

TORQUE TO 160 FT-LBS (LUBRICATED) / 210 FT-LBS (DRY).

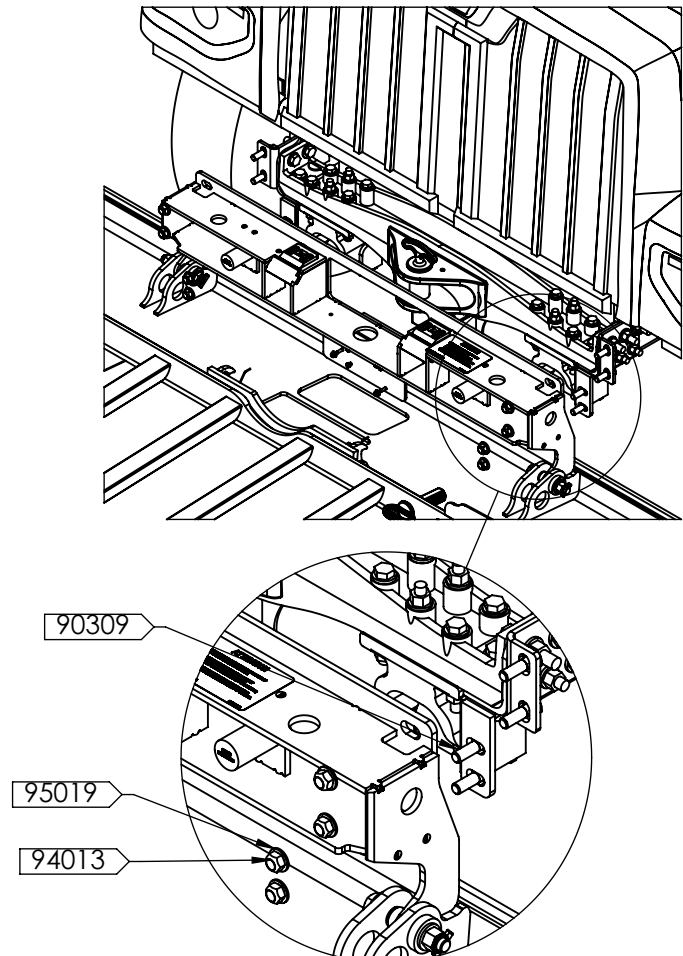





## INSTALLATION PROCEDURE

### NOTE:

**RADAR MUST BE ALIGNED AND RE-CALIBRATED AFTER BUMPER INSTALLATION. ALIGNMENT AND CALIBRATION CAN ONLY BE DONE BY AUTHORIZED PERSONNEL.**

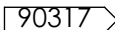
8. INSTALL THE RADAR ON THE RADAR PLATE USING THE FOLLOWING HARDWARE:

3 X  BOLTS

3 X  NUTS

TORQUE TO 6 FT-LBS (LUBRICATED) / 8 FT-LBS (DRY).

9. INSTALL THE RADAR COVER ON THE RADAR PLATE USING THE FOLLOWING HARDWARE:

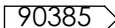
3 X  BOLTS

3 X  NUTS

3 X  WASHERS

TORQUE TO 6 FT-LBS (LUBRICATED) / 8 FT-LBS (DRY).

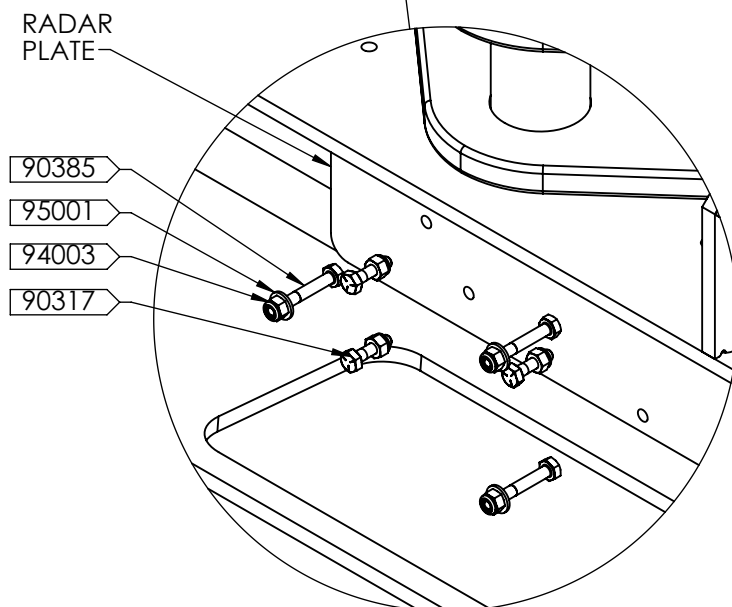
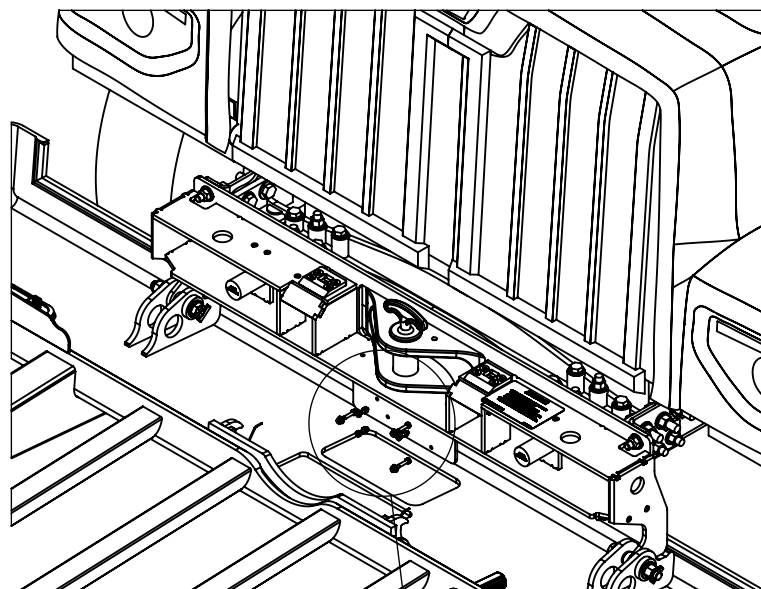

CLOSE THE BUMPER WITH CARE AND:

**A.** REVIEW FOR ANY INTERFERENCES THAT MIGHT OCCUR.

**B.** CHECK FOR ANY UNWANTED RATTLES OR MOVEMENTS OF THE BUMPER.

IF YOU HAVE ANY QUESTIONS OR CONCERNS PLEASE REACH OUT TO US.

IF EVERYTHING LOOKS GOOD, THE INSTALL IS COMPLETE, AND PLEASE REMEMBER TO CHECK FOR RATTLES AND UNWANTED MOVEMENTS PERIODICALLY. IF LATCH REQUIRES ADJUSTMENTS, INSTRUCTIONS CAN BE FOUND ON OUR WEBSITE (<https://magnumtrailer.com/resources/moose-bumper-maintenance-service-instructions/>).

THANK YOU FOR CHOOSING MAGNUM.