

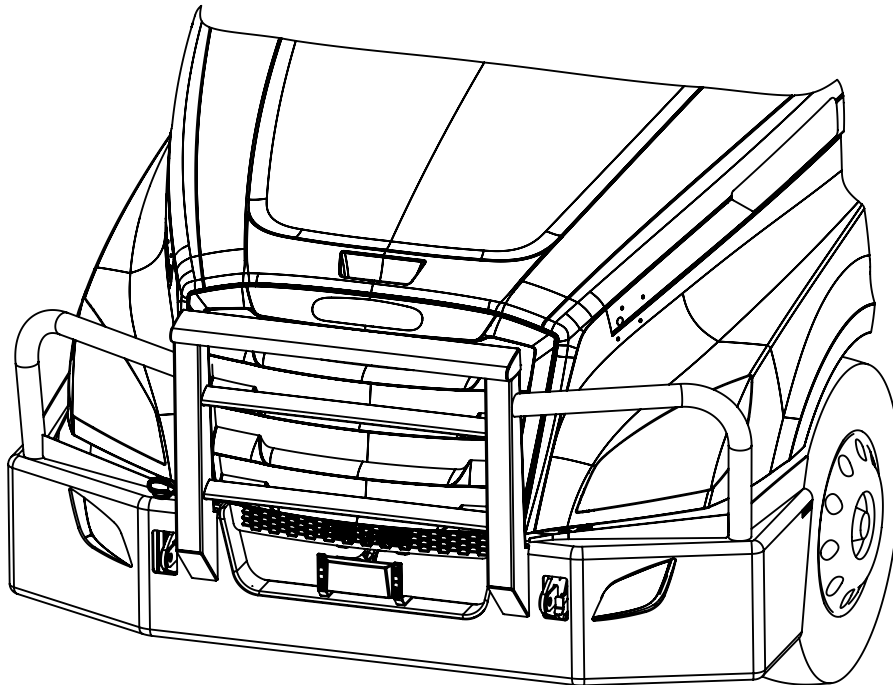

INSTALLATION GUIDE

MODEL NUMBER: 17240

TRUCK MODEL: 2017+ FREIGHTLINER CASCADIA



IMPORTANT INFORMATION

- THIS GUIDE IS ONLY APPLICABLE TO PRODUCTS AND TRUCK MODELS SPECIFIED.
- THE CORRECT SIZE AND GRADE OF HARDWARE SPECIFIED IN THIS GUIDE MUST BE USED.
- CHECK ALL MOUNTING POINTS AFTER THE FIRST 5000KM'S IN SERVICE AND PERIODICALLY THERE AFTER. RE-TORQUE IF NECESSARY.
- RECOMMENDED ADDING THREADLOCKER (LOCTITE BLUE 242) TO ALL THREADS BEFORE INSTALLING.
- ALL MAGNUM PRODUCTS MUST BE INSTALLED ACCORDING TO THIS INSTALLATION GUIDE. ANY DEVIATIONS MAY RESULT IN VOID OF WARRANTY.
- ANY ALTERATIONS TO THE PRODUCT MAY RESULT IN VOID OF WARRANTY.

SAFETY INFORMATION

- PROPER PERSONAL PROTECTIVE EQUIPMENT MUST BE WORN WHEN INSTALLING THIS PRODUCT.
- SOME PARTS OF THIS PRODUCT MAY BE HEAVY OR AWKWARD TO HANDLE. USE CAUTION WHEN HANDLING.

17240 MOOSE BUMPER

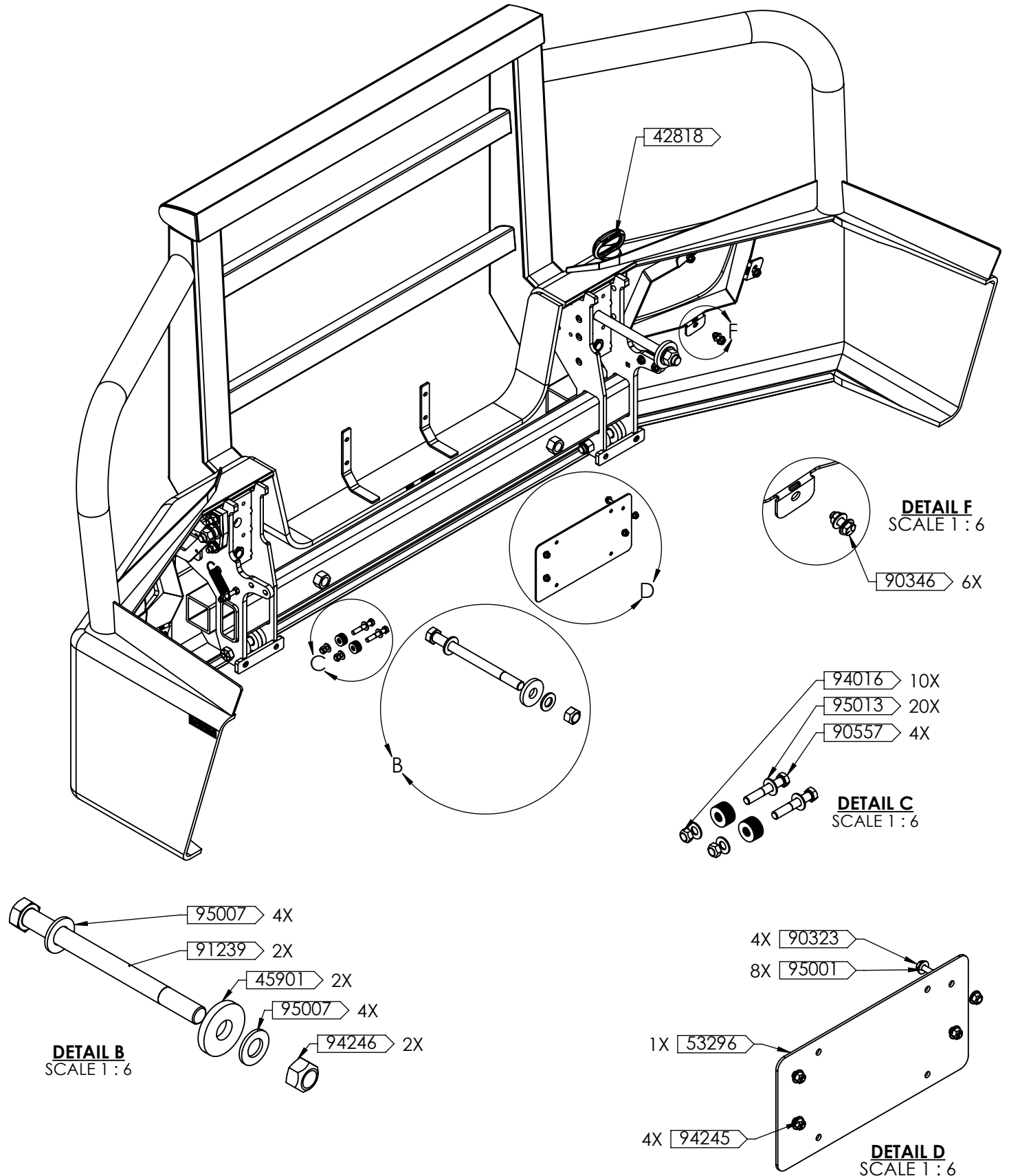

SEE NEXT PAGE FOR LIST OF PARTS INCLUDED



ASSEMBLY KIT PARTS

ITEM#	DWG	DESCRIPTION	MAT'L	DIMENSIONS	WT. EA	STOCK #	QTY.
42818	PA	CAST TOWPIN	130-90-09 CAST IRON	SEE PA - 42818	5.4	125613	1
45901	PA	WASHER PLATE	44W	SEE PA - 45901	.49	126464	2
53296	PA	COVER PLATE	5052-H32	SEE PA - 53296	.95	128099	1
90323		HEX HEAD BOLT - PLATED	GR. 5	1/4" NC X 3/4"	.019	101564	4
90346		HEX HEAD BOLT - PLATED	GR. 5	3/8 NC X 1"	.049	101654	6
90557		HEX CAPSCREW - PLATED	GR. 8	3/8" NC X 2 1/4"	.088	126450	4
91239		HEX CAPSCREW - PLATED	GR. 8	7/8" NC X 1 1/2"	2.1	126380	2
94016		STOVER NUT - PLATED	GR. C	3/8" NC	.013	101478	10
94245		STOVER NUT - PLATED	GR. C	1/4 NC	.0082	101476	4
94246		STOVER NUT - PLATED	GR. C	7/8 NC	.19	101480	2
95001		FLAT WASHER - PLATED	GR. 2	1/4" DIA SAE	.0043	102157	8
95007		FLAT WASHER - PLATED	GR. 8	7/8" DIA SAE	.078	102173	4
95013		FLAT WASHER - PLATED	GR. 8	3/8" DIA SAE	.0069	102170	20
95077		FLAT WASHER - PLATED	GR. 2	3/8" DIA USS	.015	105722	28

INSTALLATION PROCEDURE

1. UNINSTALL THE OEM BUMPER FROM THE TRUCK. REMOVE THE PASSENGER SIDE AND DRIVER SIDE DRIVING LIGHTS FROM BUMPER.

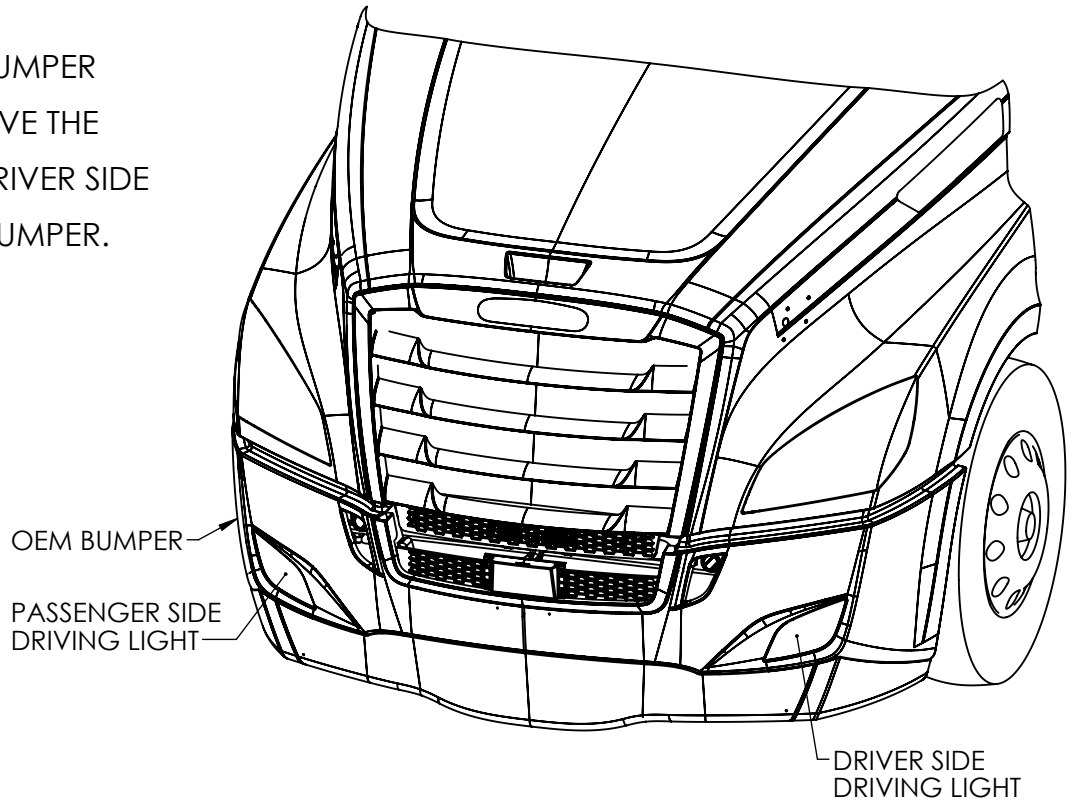

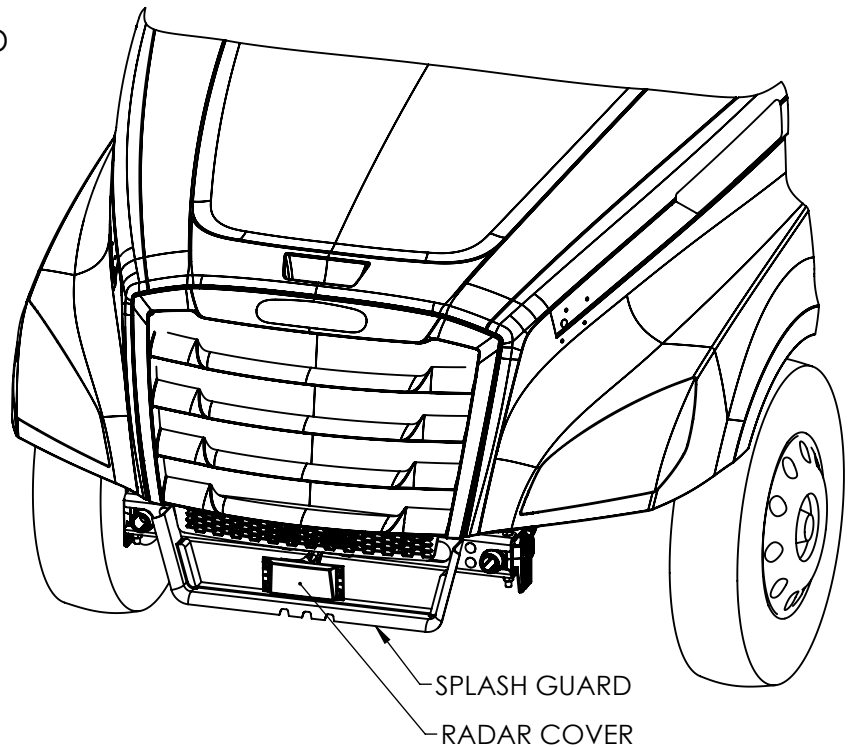

2. UNINSTALL THE SPLASH GUARD AND RADAR COVER. KEEP THE RADAR COVER TO INSTALL ON THE BUMPER LATER IF EQUIPPED.



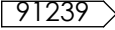

INSTALLATION PROCEDURE

4. SECURE THE BUMPER TO THE TOW RECIEVERS USING THE FOLLOWING HARDWARE:

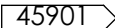
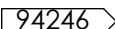

- 2 X  BOLT
- 4 X  WASHERS
- 2 X  PLATE WASHER
- 2 X  NUTS

TORQUE TO 450 FT-LBS (LUBRICATED) / 600 FT-LBS (DRY).

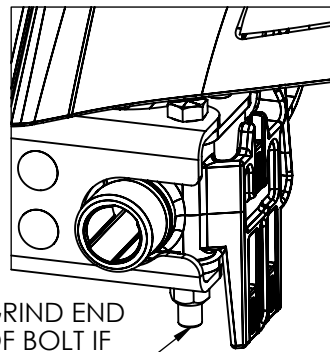
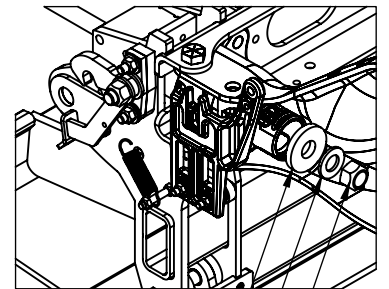
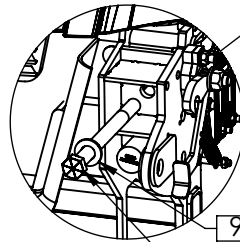
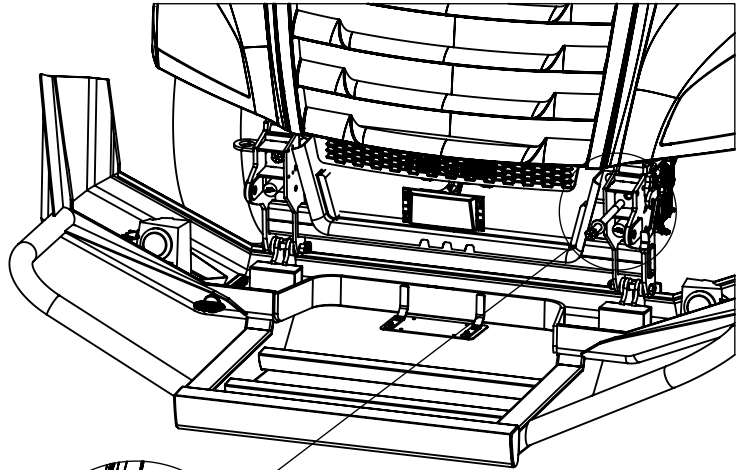
IF REQUIRED GRIND THE END OF THE BOLT INDICATED IN THE FIGURE. THIS MAY BE NEEDED FOR BUMPER TO SIT SECURELY AGAINST THE FRAME OF THE TRUCK.

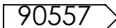

5. ATTACH THE BUMPER TO THE SIDE BRACKETS OF THE TRUCK USING THE FOLLOWING HARDWARE:

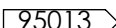
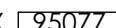
- 4 X  BOLTS
- 4 X  NUTS
- 8 X  WASHERS
- 28 X  WASHERS

USE THE  WASHERS AS SPACERS BETWEEN THE BUMPER AND THE TRUCK SIDE BRACKET

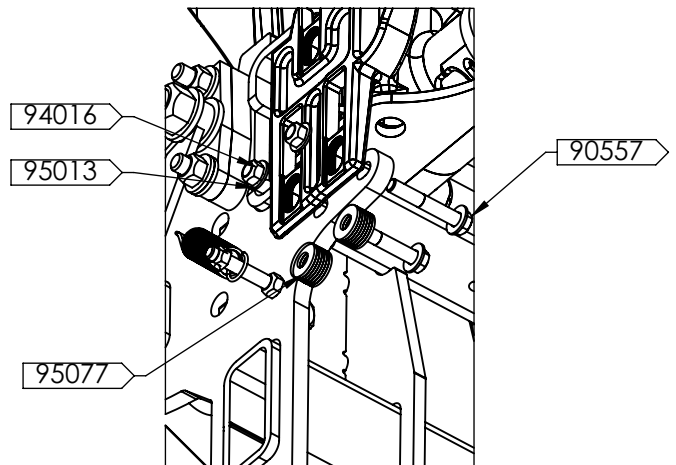

TORQUE TO 35 FT-LBS (LUBRICATED) / 45 FT-LBS (DRY).





INSTALLATION PROCEDURE

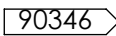
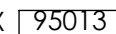

4. INSTALL THE DRIVING LIGHTS IN THE BUMPER USING THE FOLLOWING HARDWARE:

- 6 X  BOLT
- 12 X  WASHERS
- 6 X  NUTS

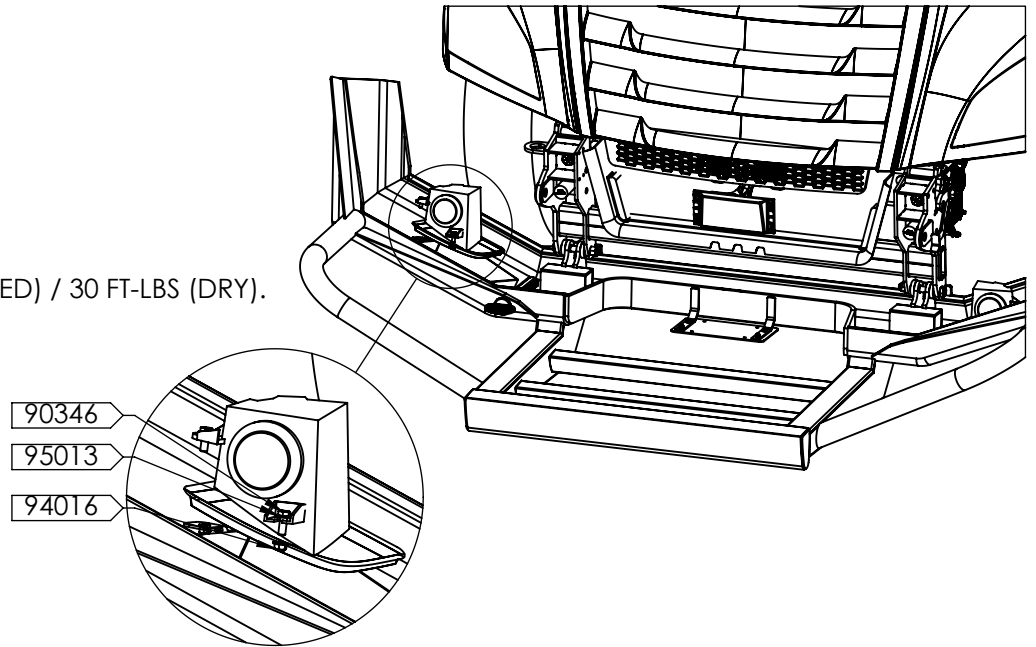
TORQUE TO 23 FT-LBS (LUBRICATED) / 30 FT-LBS (DRY).

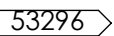

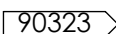
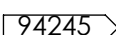
5. IF THE TRUCK IS EQUIPPED WITH RADAR INSTALL THE RADAR COVER ON THE MOUNT TABS OF THE BUMPER. IF NO RADAR IS EQUIPPED INSTALL THE ALUMINUM COVER PLATE . THE LICENCE PLATE CAN BE MOUNTED ON THIS PLATE USING THE ADDITIONAL HOLES. ATTACH EITHER OF THE COMPONENTS USING THE FOLLOWING HARDWARE:

- 4 X  BOLTS
- 4 X  NUTS
- 8 X  WASHERS

TORQUE TO 6 FT-LBS (LUBRICATED) / 8 FT-LBS (DRY).

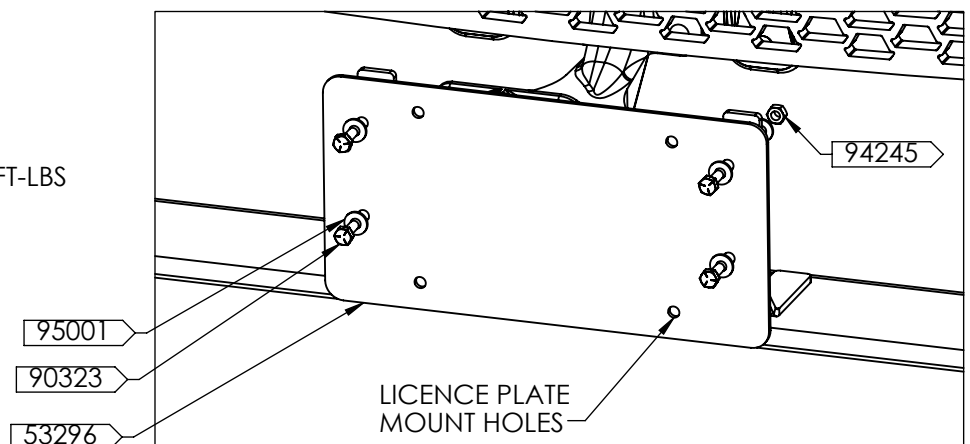
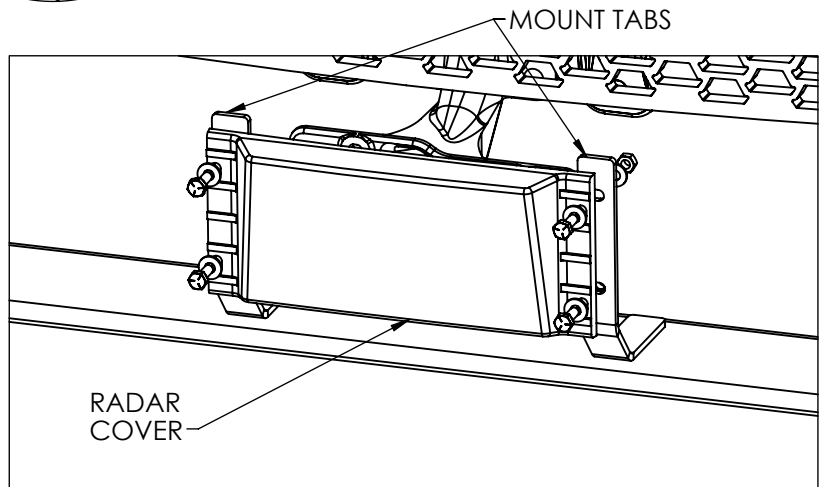



LATCH ADJUSTMENT INSTRUCTIONS

IF NEEDED, HERE ARE THE STEPS ON HOW TO ADJUST THE BUMPER LATCH:

1. SLIGHTLY LOOSEN THE 1/2" LATCH ADJUSTER BOLT.
2. USING A HAMMER, TAP/ PUSH IN THE LATCH ADJUSTER FOR A MORE TIGHTER LATCH CLOSURE, OR TAP/PULL OUT THE LATCH ADJUSTER IF BUMPER NO LONGER FULLY CLOSES.
3. CHECK IF BUMPER CAN FULLY CLOSE.
4. TIGHTEN FIRMLY THE 1/2" LATCH ADJUSTER BOLT.

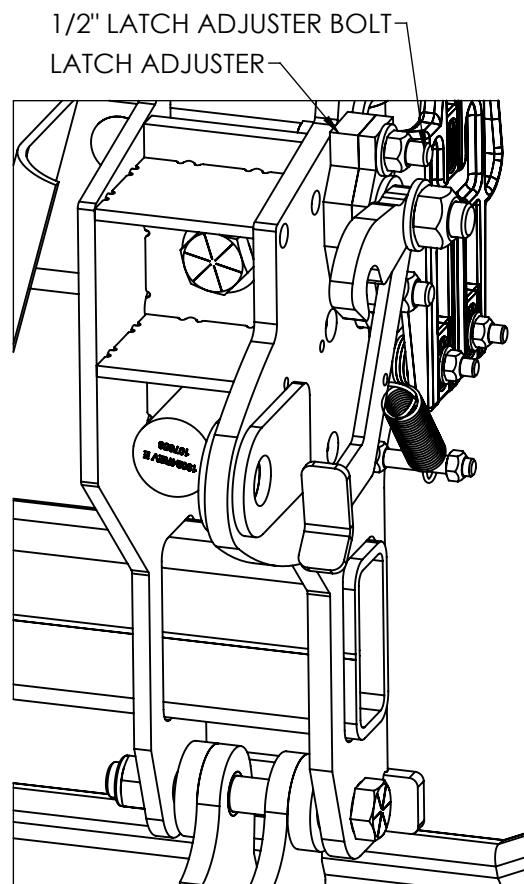

CLOSE THE BUMPER WITH CARE AND:

- A.** REVIEW FOR ANY INTERFERENCES THAT MIGHT OCCUR.
- B.** CHECK FOR ANY UNWANTED RATTLES OR MOVEMENTS OF THE BUMPER.

IF YOU HAVE ANY QUESTIONS OR CONCERNS PLEASE REACH OUT TO US.

IF EVERYTHING LOOKS GOOD, THE INSTALL IS COMPLETE, AND PLEASE REMEMBER TO CHECK FOR RATTLES AND UNWANTED MOVEMENTS PERIODICALLY.

THANK YOU FOR CHOOSING MAGNUM.