

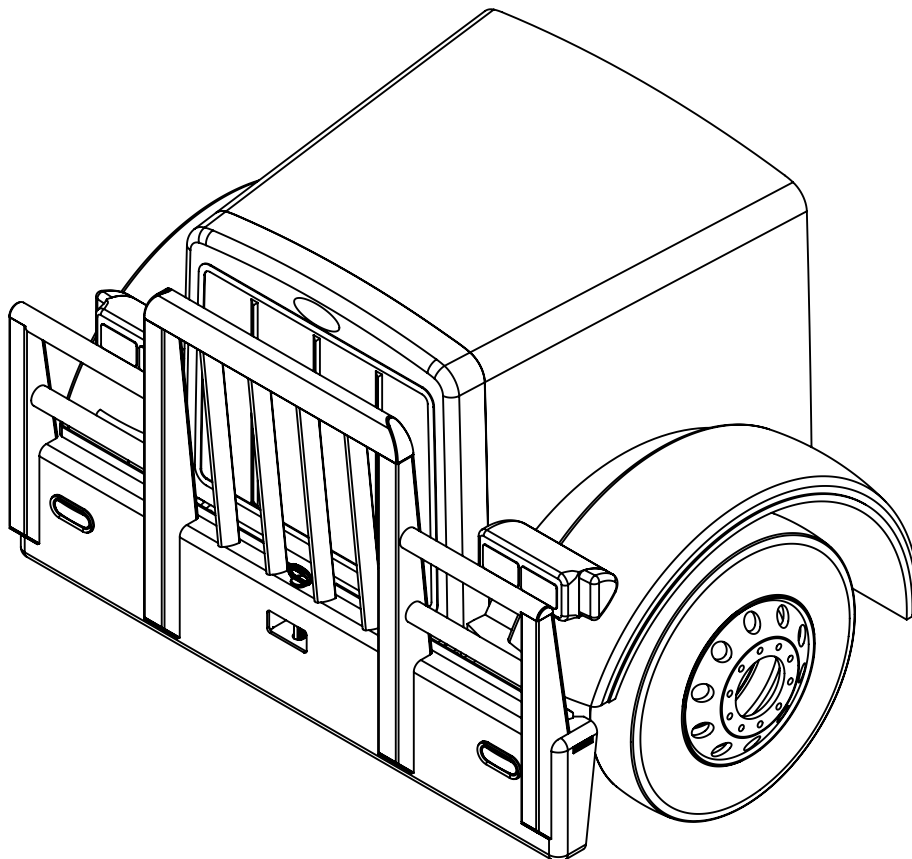

INSTALLATION GUIDE

MODEL NUMBER: 17063

TRUCK MODEL: 2004+ PETERBILT 378/379



IMPORTANT INFORMATION

- THIS GUIDE IS ONLY APPLICABLE TO PRODUCTS AND TRUCK MODELS SPECIFIED.
- THE CORRECT SIZE AND GRADE OF HARDWARE SPECIFIED IN THIS GUIDE MUST BE USED.
- CHECK ALL MOUNTING POINTS AFTER THE FIRST 5000KM'S IN SERVICE AND PERIODICALLY THERE AFTER. RE-TORQUE IF NECESSARY.
- RECOMMENDED ADDING THREADLOCKER (LOCTITE BLUE 242) TO ALL THREADS BEFORE INSTALLING.
- ALL MAGNUM PRODUCTS MUST BE INSTALLED ACCORDING TO THIS INSTALLATION GUIDE. ANY DEVIATIONS MAY RESULT IN VOID OF WARRANTY.
- ANY ALTERATIONS TO THE PRODUCT MAY RESULT IN VOID OF WARRANTY.

SAFETY INFORMATION

- PROPER PERSONAL PROTECTIVE EQUIPMENT MUST BE WORN WHEN INSTALLING THIS PRODUCT.
- SOME PARTS OF THIS PRODUCT MAY BE HEAVY OR AWKWARD TO HANDLE. USE CAUTION WHEN HANDLING.

17063 MOOSE BUMPER

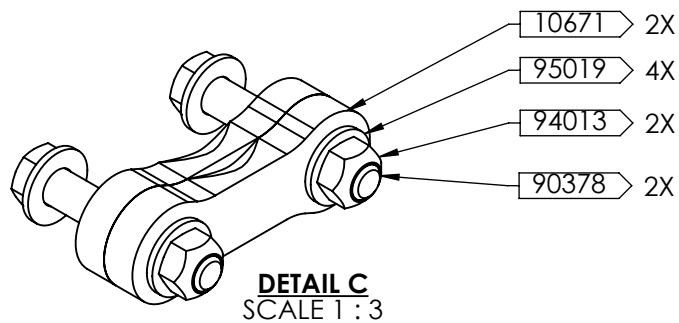
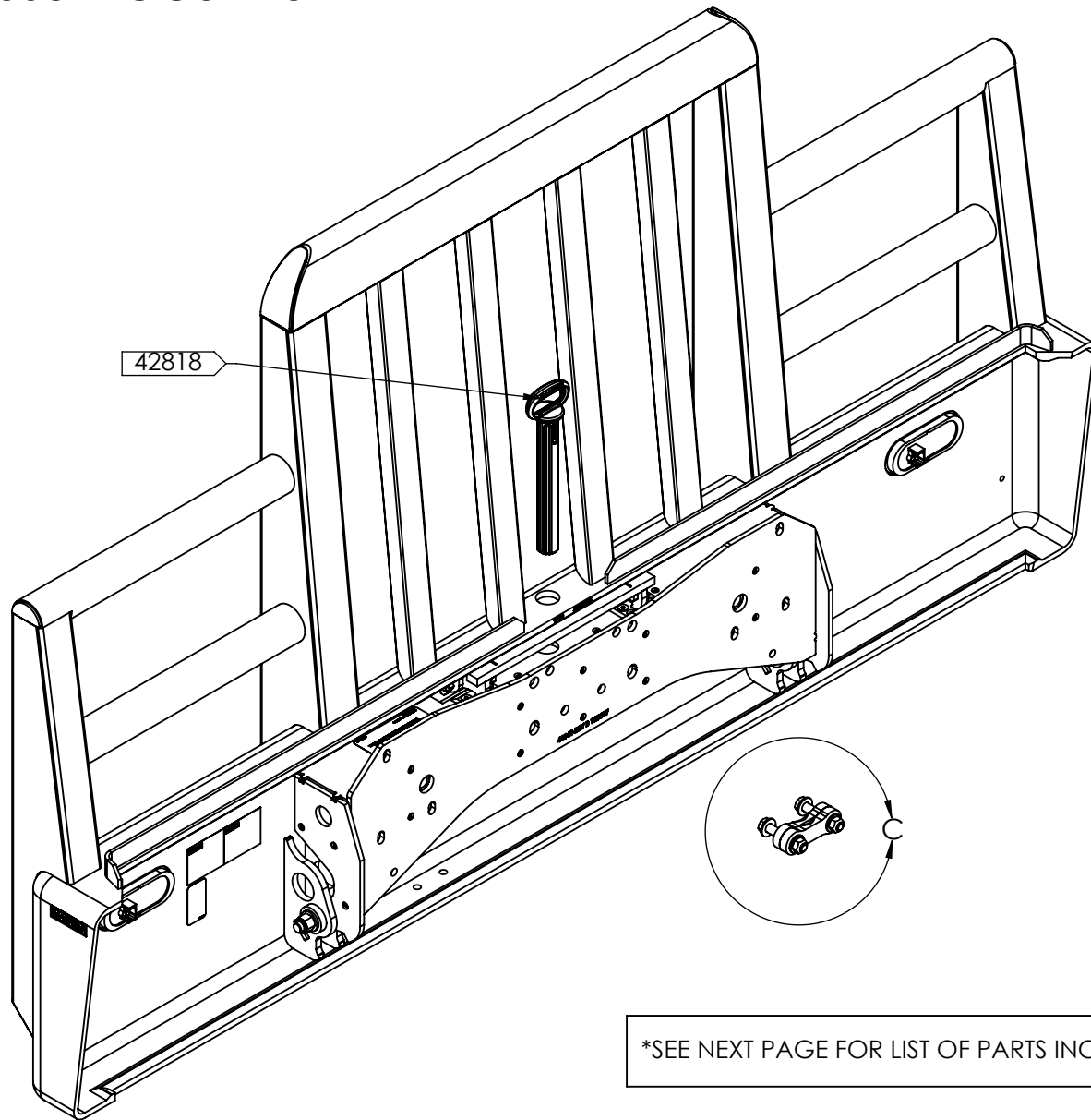



ASSEMBLY KIT PARTS

ITEM#	DWG	DESCRIPTION	MAT'L	DIMENSIONS	WT. EA	STOCK #	QTY.
10671	PA	HOOK STRAP BACKING	44W	SEE PA - 10671	1.1	102881	2
42818	PA	CAST TOWPIN	130-90-09 CAST IRON	SEE PA - 42818	5.4	125613	1
90378		HEX HEAD BOLT - PLATED	GR. 8	5/8" NC X 3 1/2"	.38	101981	2
94013		STOVER NUT - PLATED	GR. C	5/8" NC	.063	101481	2
95019		FLAT WASHER - PLATED	GR. 8	5/8" DIA SAE	.035	102172	4

INSTALLATION PROCEDURE

1. UNINSTALL THE OEM BUMPER FROM THE TRUCK .

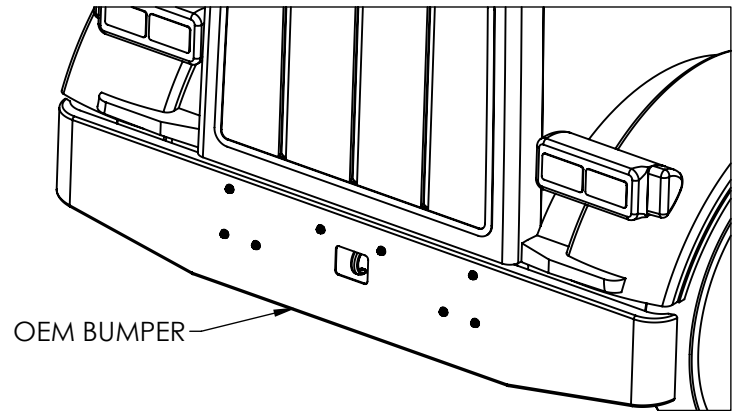

2. PLACE A STRAIGHT EDGE OVER THE TOW HOOK AND BUMPER MOUNT FACES. IF THE HOOK PROTRUDES FORWARD OF THE BUMPER MOUNT FACE, ADDITIONAL WASHERS WILL BE NEEDED AS SPACERS FOR BETWEEN THE TRUCK AND INSTALLED BUMPER.

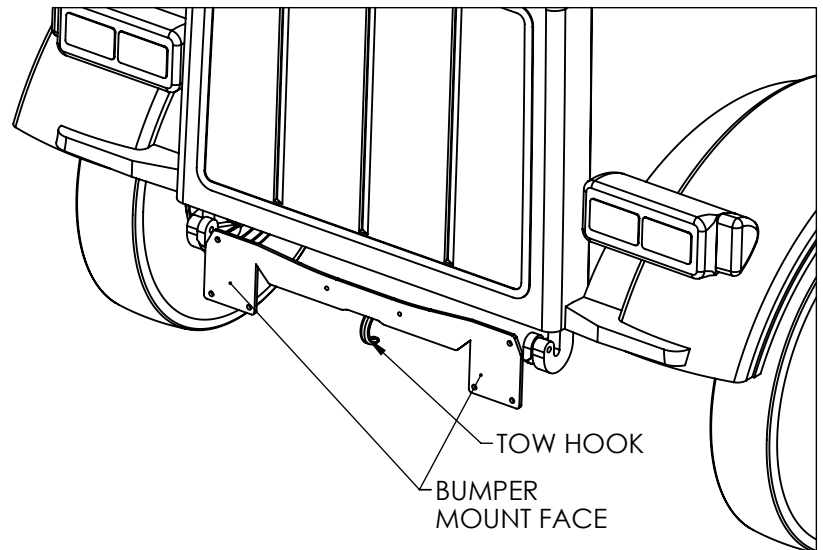

NOTE:

WHEN INSTALLING THE BUMPER, CHECK THAT THE DISTANCE BETWEEN THE TOP OF GRILL AND THE BUMPER IS AROUND 4" - 4 1/2" AS SEEN IN THE FIGURE TO THE RIGHT.

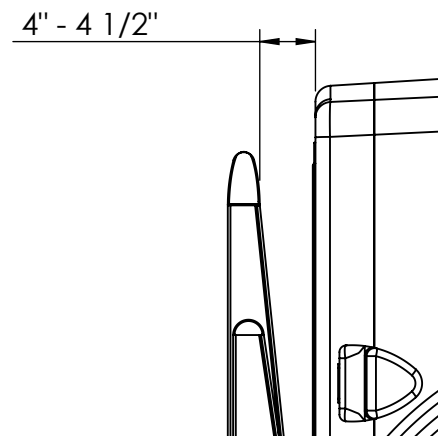



INSTALLATION PROCEDURE

3. OPEN THE BUMPER AND ATTACH THE STEEL ASSEMBLY TO THE TRUCK FRAME, USING THE FOLLOWING HARDWARE:

- 2 X 1/2" NC X 1 1/2" GR.8 HEX BOLT (NOT SUPPLIED)
- 14 X 1/2" GR.8 FLAT WASHER (NOT SUPPLIED)
- 6 X 1/2" NC X 1 3/4" GR.8 HEX BOLT (NOT SUPPLIED)
- 6 X 1/2" STOVER NUT GR.C (NOT SUPPLIED)

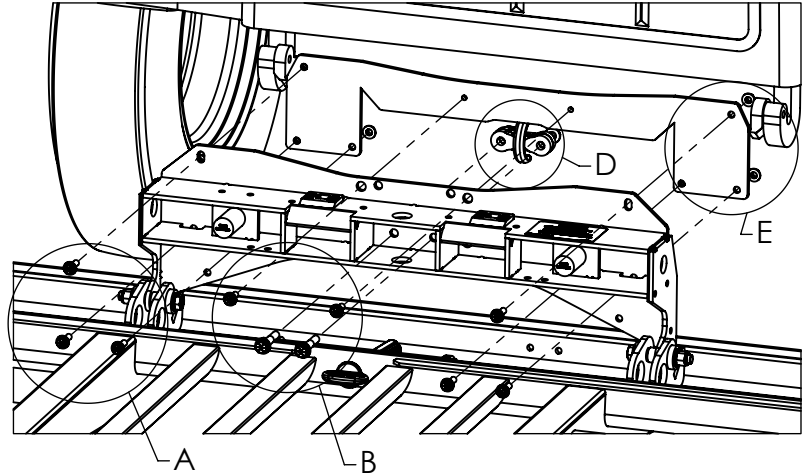

TORQUE TO 80 FT-LBS (LUBRICATED) / 110 FT-LBS (DRY).

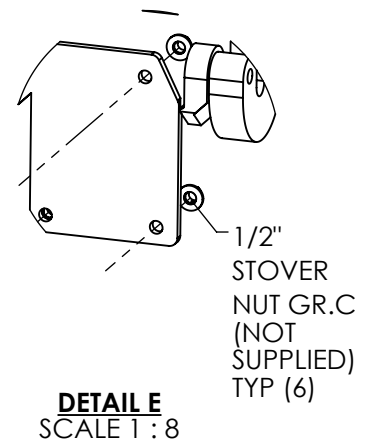
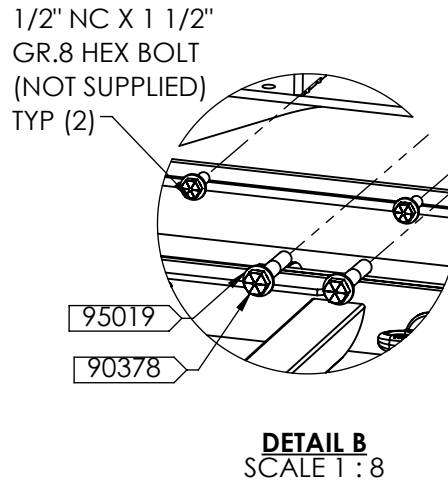
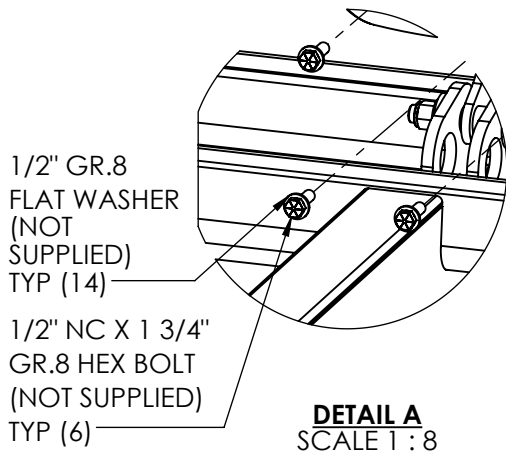

4. PLACE THE TWO T0671 HOOK STRAPS BEHIND THE TOW HOOK AND SECURE THEM USING THE FOLLOWING HARDWARE:

- 2 X 90378 HEX BOLT (SUPPLIED)
- 4 X 95019 FLAT WASHER (SUPPLIED)
- 94013 2X STOVER NUTS (SUPPLIED)

TORQUE TO 159 FT-LBS (LUBRICATED) / 212 FT-LBS (DRY).

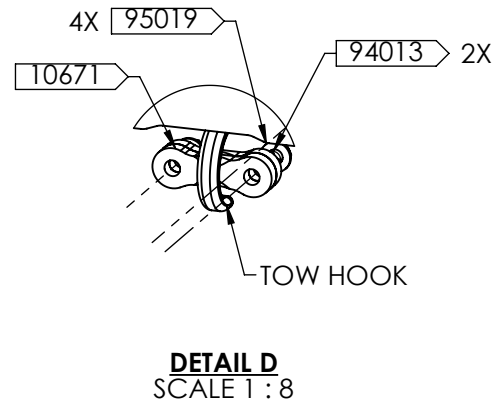



INSTALLATION PROCEDURE

5. (OPTIONAL) DRILL THROUGH THE TRUCK FRAME AND ADD ADDITIONAL 1/2" GR.8 HARDWARE IN ORDER TO IMPROVE THE TOWING CONNECTION.

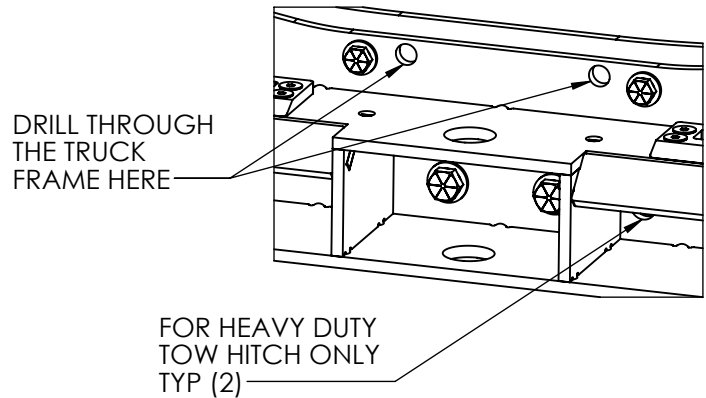

CLOSE THE BUMPER WITH CARE AND:

- A. REVIEW FOR ANY INTERFERENCES THAT MIGHT OCCUR.
- B. CHECK FOR ANY UNWANTED RATTLES OR MOVEMENTS OF THE BUMPER.

IF YOU HAVE ANY QUESTIONS OR CONCERNS PLEASE REACH OUT TO US.

IF EVERYTHING LOOKS GOOD, THE INSTALL IS COMPLETE, BUT PLEASE REMEMBER TO CHECK FOR RATTLES AND UNWANTED MOVEMENTS PERIODICALLY. IF LATCH REQUIRES ADJUSTMENTS, INSTRUCTIONS CAN BE FOUND ON OUR WEBSITE (<https://magnumtrailer.com/resources/moose-bumper-maintenance-service-instructions/>). THANK YOU FOR CHOOSING MAGNUM.