

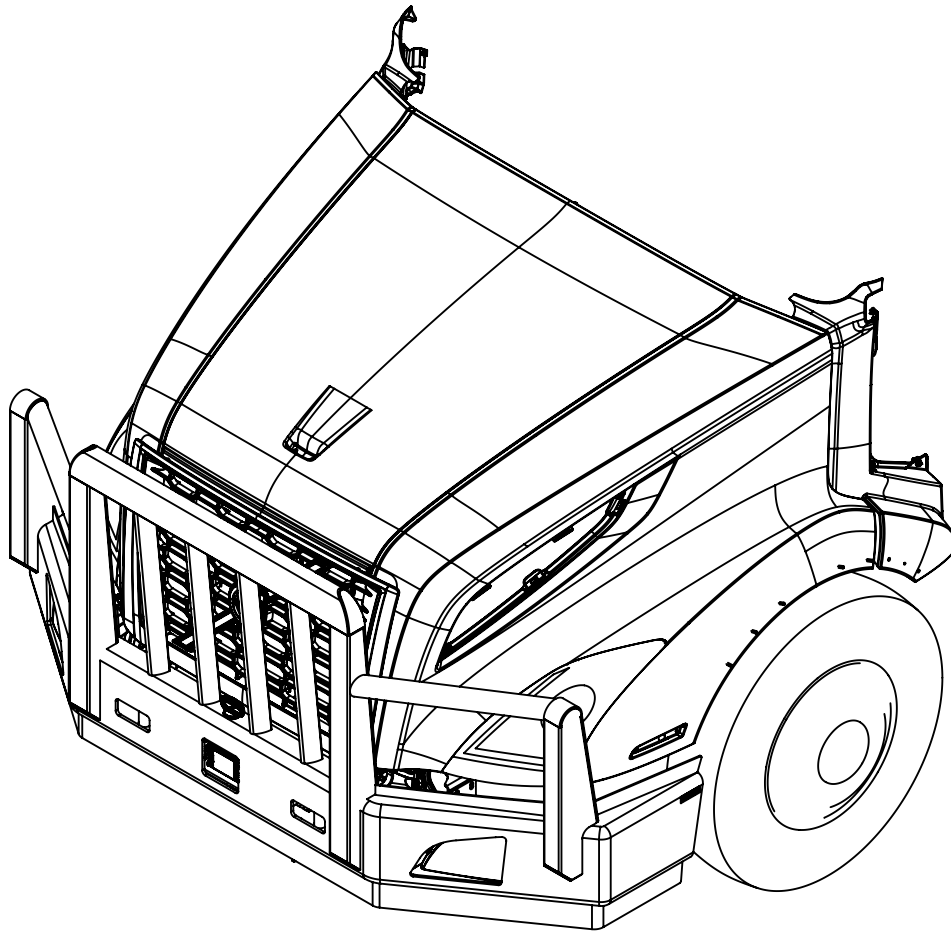

INSTALLATION GUIDE

MODEL NUMBER: 17288

TRUCK MODEL: 2018+ VOLVO VNL



IMPORTANT INFORMATION

- THIS GUIDE IS ONLY APPLICABLE TO PRODUCTS AND TRUCK MODELS SPECIFIED.
- THE CORRECT SIZE AND GRADE OF HARDWARE SPECIFIED IN THIS GUIDE MUST BE USED.
- CHECK ALL MOUNTING POINTS AFTER THE FIRST 5000KM'S IN SERVICE AND PERIODICALLY THERE AFTER. RE-TORQUE IF NECESSARY.
- RECOMMENDED ADDING THREADLOCKER (LOCTITE BLUE 242) TO ALL THREADS BEFORE INSTALLING.
- ALL MAGNUM PRODUCTS MUST BE INSTALLED ACCORDING TO THIS INSTALLATION GUIDE. ANY DEVIATIONS MAY RESULT IN VOID OF WARRANTY.
- ANY ALTERATIONS TO THE PRODUCT MAY RESULT IN VOID OF WARRANTY.

SAFETY INFORMATION

- PROPER PERSONAL PROTECTIVE EQUIPMENT MUST BE WORN WHEN INSTALLING THIS PRODUCT.
- SOME PARTS OF THIS PRODUCT MAY BE HEAVY OR AWKWARD TO HANDLE. USE CAUTION WHEN HANDLING.

17288 MOOSE BUMPER

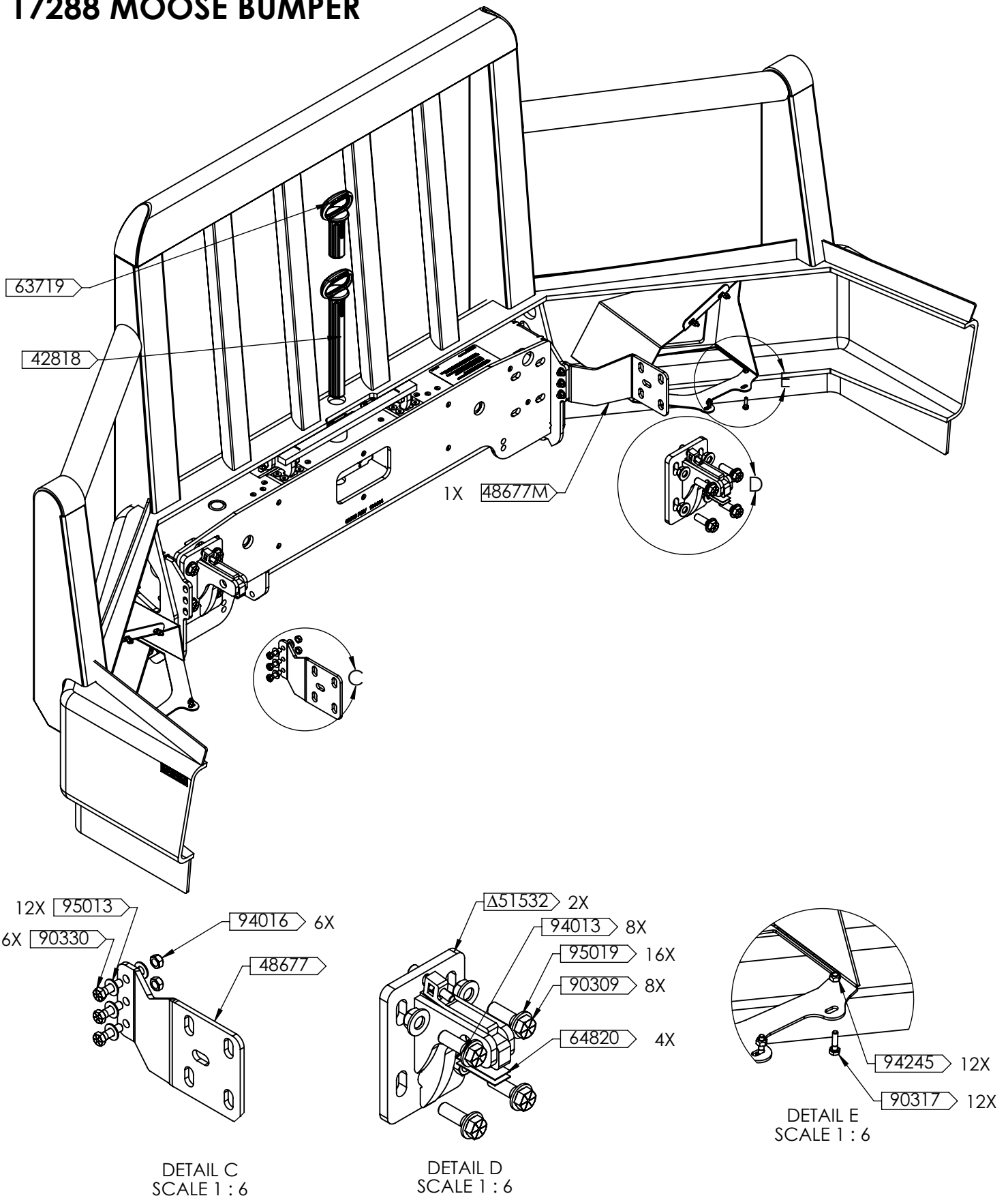

SEE NEXT PAGE FOR LIST OF PARTS INCLUDED

MODEL NUMBER: 17288
DATE: 3/13/2024
REVISION: A



ASSEMBLY KIT PARTS

ITEM#	DESCRIPTION	MAT'L	DIMENSIONS	WT. EA	STOCK #	QTY.
42818	CAST TOWPIN	130-90-09 CAST IRON	Ø1 1/2 X 13 5/8	5.4	125613	1
48677	MOUNT BRACKET	44W	1/4" PL X 11 9/16" X 6 3/8"	3.4	126855	1
48677M	MOUNT BRACKET - MIRROR	44W	1/4" PL X 11 9/16" X 6 3/8"	3.4	126856	1
51532	MOUNT BRACKET ASSEMBLY		ASSEMBLY	9.9	127513	2
51975	BENDIX RADAR (FLR-20) MOUNTING BRACKET (VER 3)	5052-H32	1/8" X 10 29/32" X 4 1/4"	.47	127701	1
63719	SHORT CAST LATCH PIN (4-1/2 IN)	65-45-12 CAST IRON	Ø1 1/2 X 6 3/4	2.8	131663	1
64820	TOW RECEIVER SHIM	Galvanized Steel	1/32" (20 GA.) X 1" X 2 1/2"	.028	131878	4
90309	HEX CAPSCREW - PLATED	GR. 8	5/8" NC X 2"	.25	101976	8
90317	HEX CAPSCREW - PLATED	GR. 5	1/4" NC X 1"	.022	101551	12
90330	HEX CAPSCREW - PLATED	GR. 8	3/8" NC X 1 1/4"	.056	101903	6
94013	STOVER NUT - PLATED	GR. C	5/8" NC	.063	101481	8
94016	STOVER NUT - PLATED	GR. C	3/8" NC	.013	101478	6
94245	STOVER NUT - PLATED	GR. C	1/4 NC	.0082	101476	12
95013	FLAT WASHER - PLATED	GR. 8	3/8" DIA SAE	.0069	102170	12
95019	FLAT WASHER - PLATED	GR. 8	5/8" DIA SAE	.035	102172	16



INSTALLATION PROCEDURE

1. UNINSTALL THE OEM BUMPER FROM THE TRUCK AND UNINSTALL THE FOG LIGHTS FROM THE BUMPER.

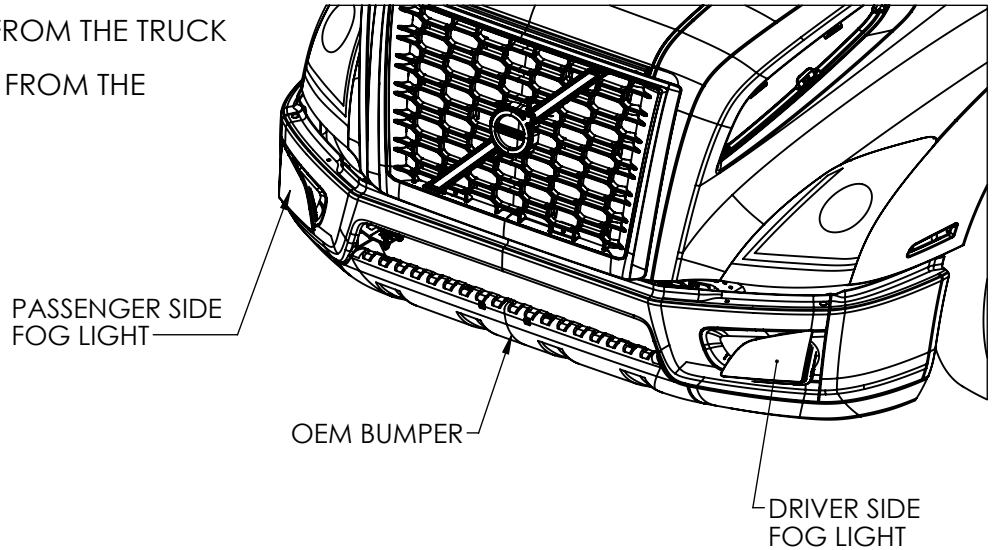

2. IF RADAR IS EQUIPPED ON THE TRUCK IT MUST BE REMOVED FIRST BEFORE INSTALLING THE MOOSE BUMPER. KEEP THE ORIGINAL MOUNTING HARDWARE SEEN IN THE FIGURE TO THE RIGHT:

- 3 X ADJUSTABLE STANDOFFS
- 3 X ADJUSTMENT SCREWS
- 6 X TORX SCREWS

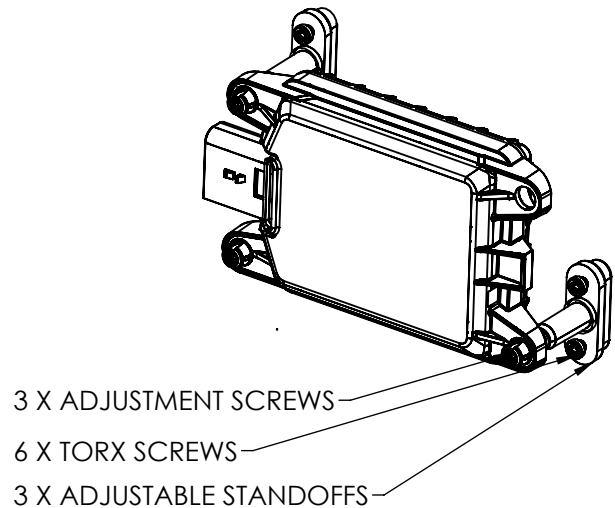

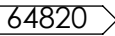
3. LOOSEN THE SCREW ON THE MOUNTING BRACKETS UNTIL IT IS ABLE TO SLIDE INTO THE TOW RECEIVERS WITH UP TO TWO SHIMS PLACED ON THE BOTTOM MOUNT FACE OF THE BRACKET ( 4X TOTAL). DEPENDING ON THE SIZE OF THE TOW RECEIVER SHIMS MAY NOT BE REQUIRED.

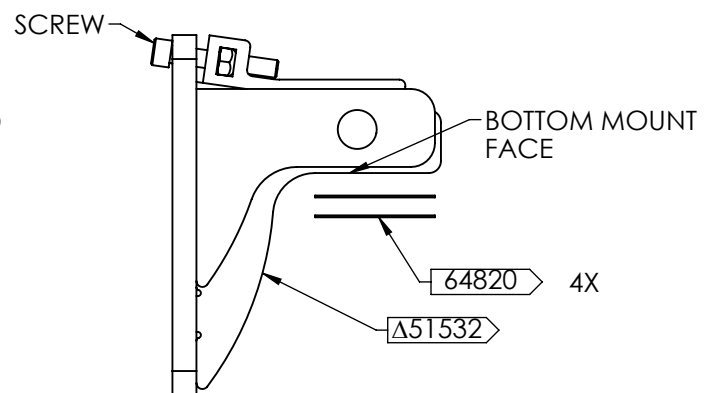



INSTALLATION PROCEDURE

4. INSTALL THE MOUNT BRACKETS

 IN BOTH TOW

RECEIVERS. SLIDE THE FACTORY
TOW PIN (OR AN EQUIVALENT 3/4"
BOLT - NOT SUPPLIED) THROUGH
THE HOLE IN BOTH THE TOW
RECEIVER AND MOUNTING
BRACKET. TIGHTEN THE SOCKET
HEAD SCREW UNTIL THE
MOUNTING BRACKET IS FULLY
SECURED.

TORQUE TO 22 FT-LBS
(LUBRICATED) / 44 FT-LBS (DRY).

5. OPEN THE BUMPER AND ATTACH

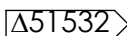
THE STEEL ASSEMBLY TO THE
 BRACKETS. USE THE

FOLLOWING HARDWARE TO
ATTACH THE GUARD:

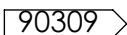
8 X  BOLTS

16 X  WASHERS

8 X  NUTS

TORQUE TO 159 FT-LBS
(LUBRICATED) / 212 FT-LBS (DRY).

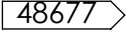
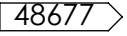

INSTALLATION PROCEDURE

6. INSTALL  ON THE DRIVER SIDE OF THE TRUCK. ATTACH  TO STEEL ASSEMBLY USING THE FOLLOWING HARDWARE:

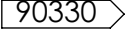
3 X  BOLTS

6 X  WASHERS

3 X  NUTS

TORQUE TO 22 FT-LBS (LUBRICATED) / 44 FT-LBS (DRY).

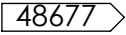
ATTACH  TO THE TRUCK USING THE ORIGINAL BUMPER HARDWARE. REPEAT FOR OTHER SIDE OF TRUCK USING 48677M.

7. INSTALL THE FOG LIGHTS INTO THE BUMPER USING THE FOLLOWING HARDWARE:

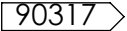
8 X  BOLTS

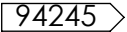
8 X  NUTS

TORQUE TO 4 FT-LBS (LUBRICATED) / 8 FT-LBS (DRY).



INSTALLATION PROCEDURE

NOTE:

RADAR MUST BE ALIGNED AND RE-CALIBRATED AFTER BUMPER INSTALLATION. ALIGNMENT AND CALIBRATION CAN ONLY BE DONE BY AUTHORIZED PERSONNEL.

8. INSTALL RADAR ONTO **51975** REUSING THE

ORIGINAL HARDWARE:

3 X ADJUSTABLE SCREWS

3 X ADJUSTABLE STANDOFFS

6 X TORX SCREWS

9. RECONNECT THE RADAR TO THE TRUCK (USE BRACKET SLOT TO FISH RADAR CABLE)

10. MOUNT THE ASSEMBLY INTO THE BUMPER USING THE FOLLOWING HARDWARE:

4 X **90317** BOLTS

4 X **94245** NUTS

TORQUE TO 4 FT-LBS (LUBRICATED) / 8 FT-LBS (DRY).

11. **42818** COMES INSTALLED ON THE BUMPER. HOWEVER, IF THE TRUCK IS EQUIPPED WITH RADAR SWITCH IT TO **63719**. THE LONGER PIN IS NOT COMPATIBLE WITH THE RADAR. CLOSE THE BUMPER TO COMPLETE THE INSTALLATION.

FIRST TIME, ALWAYS CLOSE BUMPER WITH CARE.

THANK YOU.

