

MAGNUM TRAILER & EQUIPMENT INC.

FRACTIONS CHART							
1/32	.03125	9/32	.28125	17/32	.53125	25/32	.78125
1/16	.0625	5/16	.3125	9/16	.5625	13/16	.8125
3/32	.09375	11/32	.34375	19/32	.59375	27/32	.84375
1/8	.125	3/8	.375	5/8	.625	7/8	.875
5/32	.15625	13/32	.40625	21/32	.65625	29/32	.90625
3/16	.1875	7/16	.4375	11/16	.6875	15/16	.9375
7/32	.21875	15/32	.46875	23/32	.71875	31/32	.96875
1/4	.25	1/2	.5	3/4	.75		

UNLESS OTHERWISE SPECIFIED DIMENSIONS ARE IN INCHES TOLERANCES ARE:

FRACTIONS	ANGLES
+/- 1/16"	+/- 1°
.XX"	.XXX"
+/- 0.03"	+/- 0.005"

DIMENSIONS TO SHARP POINTS

SHEET NAME	BUMPER INSTALL		
CURRENT CUSTOMER			
WO#			
SCALE	1:8		

TITLE				17282 ON 2021 PETERBILT 579			
STOCK NUMBER		VENDOR NUMBER		WEIGHT - LB.		365	
DRAWN BY	DRAWN DATE	CHECKED BY	CHECKED DATE	REV.			
DP	9/23/2021	MD	11/22/2021				
MODELLER		DRAWING NUMBER		NUMBER OF SHEETS			
MD		AA-59325		4			

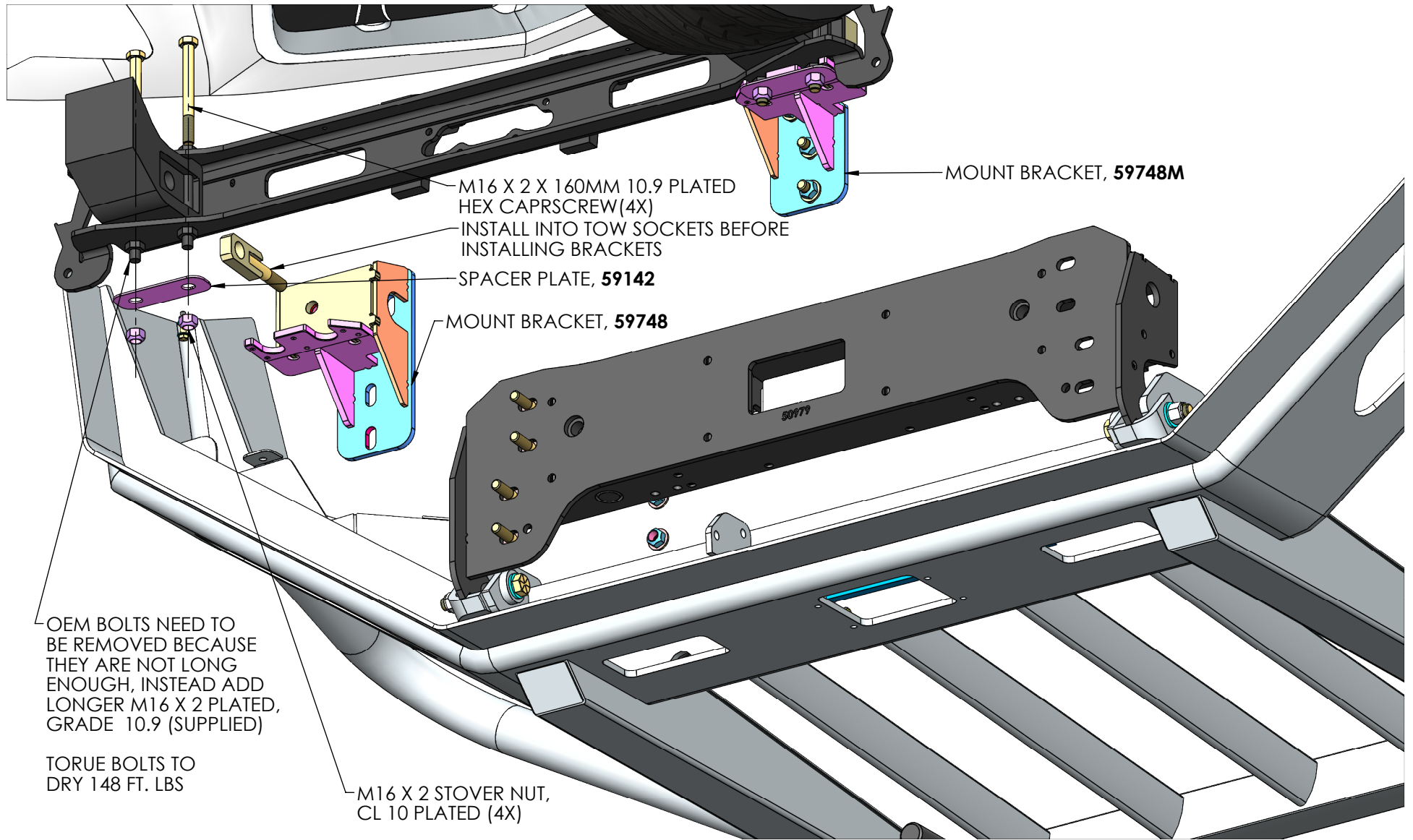

MAGNUM TRAILER & EQUIPMENT INC.



FRACTIONS CHART

1/32	.03125	9/32	.28125	17/32	.53125	25/32	.78125
1/16	.0625	5/16	.3125	9/16	.5625	13/16	.8125
3/32	.09375	11/32	.34375	19/32	.59375	27/32	.84375
1/8	.125	3/8	.375	5/8	.625	7/8	.875
5/32	.15625	13/32	.40625	21/32	.65625	29/32	.90625
3/16	.1875	7/16	.4375	11/16	.6875	15/16	.9375
7/32	.21875	15/32	.46875	23/32	.71875	31/32	.96875
1/4	.25	1/2	.5	3/4	.75		

UNLESS OTHERWISE SPECIFIED DIMENSIONS ARE IN INCHES TOLERANCES ARE:

FRACTIONS	ANGLES
± 1/16"	± 1°
.XX"	.XXX"
± 0.03"	± 0.005"

DIMENSIONS TO SHARP POINTS

SHEET NAME
BRACKET INSTALL

CURRENT CUSTOMER

WO#

SCALE

1:12

TITLE
17282 ON 2021 PETERBILT 579

STOCK NUMBER

VENDOR NUMBER

WEIGHT - LB.

365

DRAWN BY

DRAWN DATE

CHECKED BY

CHECKED DATE

REV.

DP

9/23/2021

MD

11/22/2021

MODELLER

DRAWING NUMBER

NUMBER OF SHEETS

MD

AA-59325

4

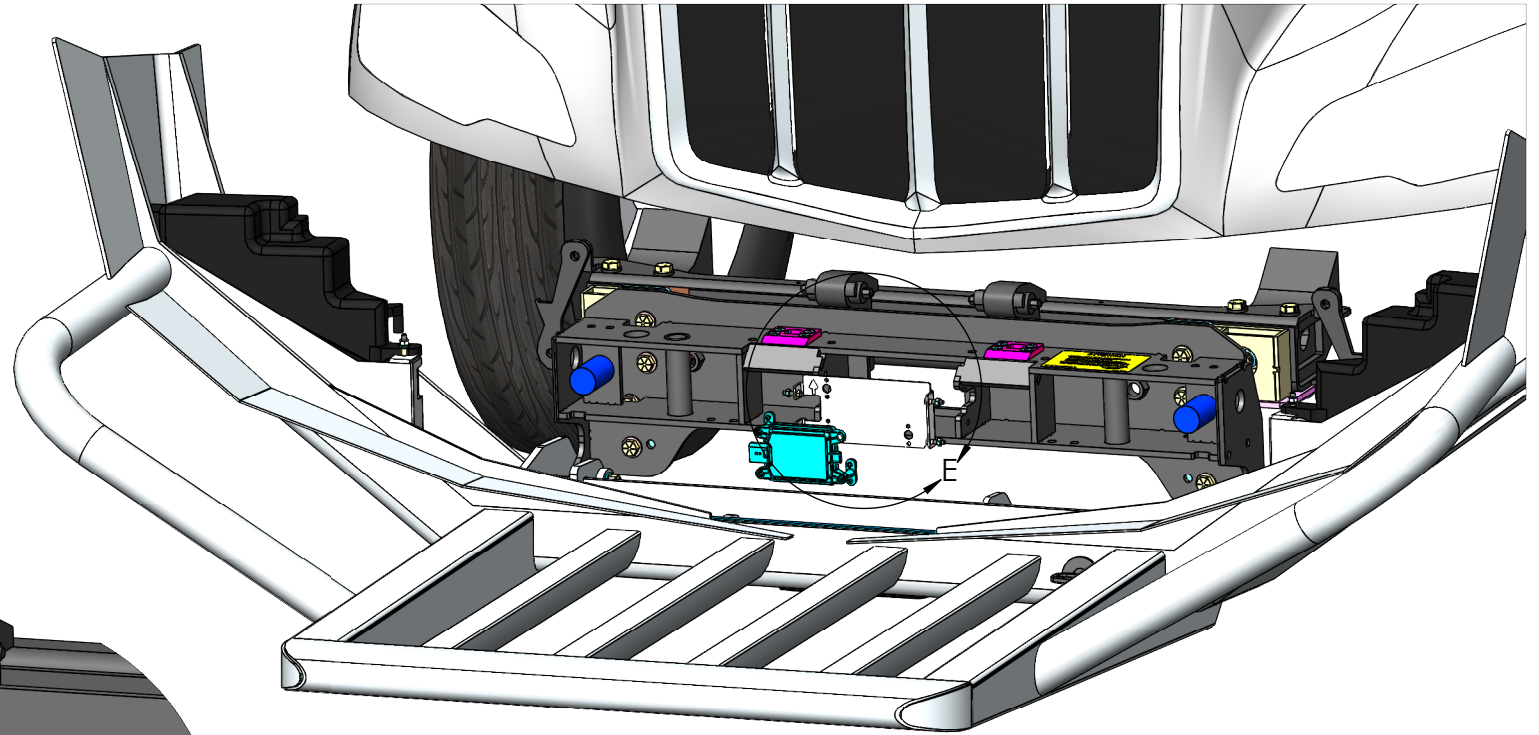

STEP (2)
 RECONNECT RADAR TO THE TRUCK (USE BRACKET SLOT TO FISH RADAR CABLE)

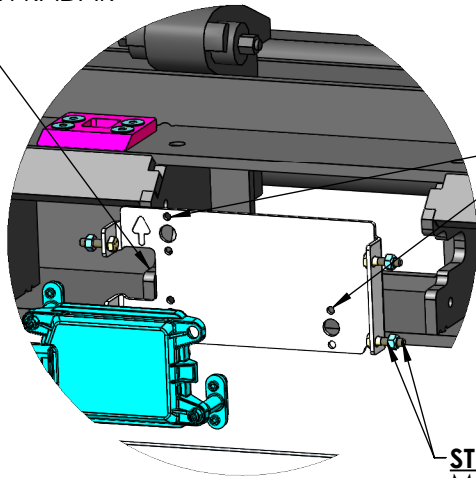

DETAIL E
SCALE 1 : 6

STEP (1)
 INSTALL RADAR INTO RADAR BRACKET SUPPLIED REUSING ORIGINAL ADJUSTABLE STAND-OFF AND FASTENERS

STEP (3)
 MOUNT RADAR BRACKET WITH RADAR INSTALLED ON IT USING 1/4" NC X 1" GR. 5 AND GR.C STOVER NUTS (SUPPLIED) 4 PLACES

NOTE:
 IF EQUIPED, RADAR MUST BE REMOVED BEFORE BUMPER INSTALLATION
 RADAR MUST BE RE-CALIBRATED AFTER BUMPER INSTALLATION.
 CALIBRATION CAN ONLY BE DONE BY AUTHORIZED PERSONNEL

MAGNUM TRAILER & EQUIPMENT INC. 	FRACTIONS CHART				UNLESS OTHERWISE SPECIFIED DIMENSIONS ARE IN INCHES TOLERANCES ARE:		SHEET NAME RADAR INSTALL		TITLE 17282 ON 2021 PETERBILT 579					
	1/32 .03125	9/32 .28125	17/32 .53125	25/32 .78125	FRACTIONS		ANGLES		CURRENT CUSTOMER		STOCK NUMBER		VENDOR NUMBER	
	1/16 .0625	5/16 .3125	9/16 .5625	13/16 .8125	+/- 1/16"		+/- 1°		DRAWN BY		DRAWN DATE		CHECKED BY	
	3/32 .09375	11/32 .34375	19/32 .59375	27/32 .84375	.XX"		.XXX"		DP		9/23/2021		MD	
1/8 .125	3/8 .375	5/8 .625	7/8 .875	+/- 0.03"		+/- 0.005"		WO#		SCALE		1:12		
5/32 .15625	13/32 .40625	21/32 .65625	29/32 .90625	DIMENSIONS TO SHARP POINTS				MODELLER		DRAWING NUMBER		NUMBER OF SHEETS		
3/16 .1875	7/16 .4375	11/16 .6875	15/16 .9375					MD		AA-59325		4		
7/32 .21875	15/32 .46875	23/32 .71875	31/32 .96875											
1/4 .25	1/2 .5	3/4 .75												