

**BUMPER INSTALL**

1. UNINSTALL OEM BUMPER FROM TRUCK. REMOVE FOG LIGHTS FROM OEM BUMPER.
2. UNINSTALL RADAR AND COVER FROM RADAR BRACKET ON FRAME
3. UNINSTALL OEM BUMPER BRACKETS AND RADAR BRACKET
4. REINSTALL THE BACK TWO BOLTS THAT ATTACHED THE OEM BUMPER BRACKET.
5. ATTACH THE BUMPER TO THE TRUCK USING THE FRONT TWO BOLT HOLES. USE THE INCLUDED HARDWARE:  
 (4) 5/8" X 2 1/4" GR.8 HEX BOLT  
 (4) 5/8" STOVER NUT  
 (24) 5/8" FLAT WASHERS
6. USE 1-4 WASHERS FOR EACH BOLT TO FILL THE SPACE BETWEEN THE STEEL ASSEMBLY AND THE FRAME OF THE TRUCK.
7. INSTALL THE RADAR AND COVER ON THE RADAR BRACKET USING THE ORIGINAL HARDWARE.
8. INSTALL FOG LIGHTS ON BUMPER (SEE FOG LIGHT SHEET).

**STEP 7:  
RADAR BRACKET**

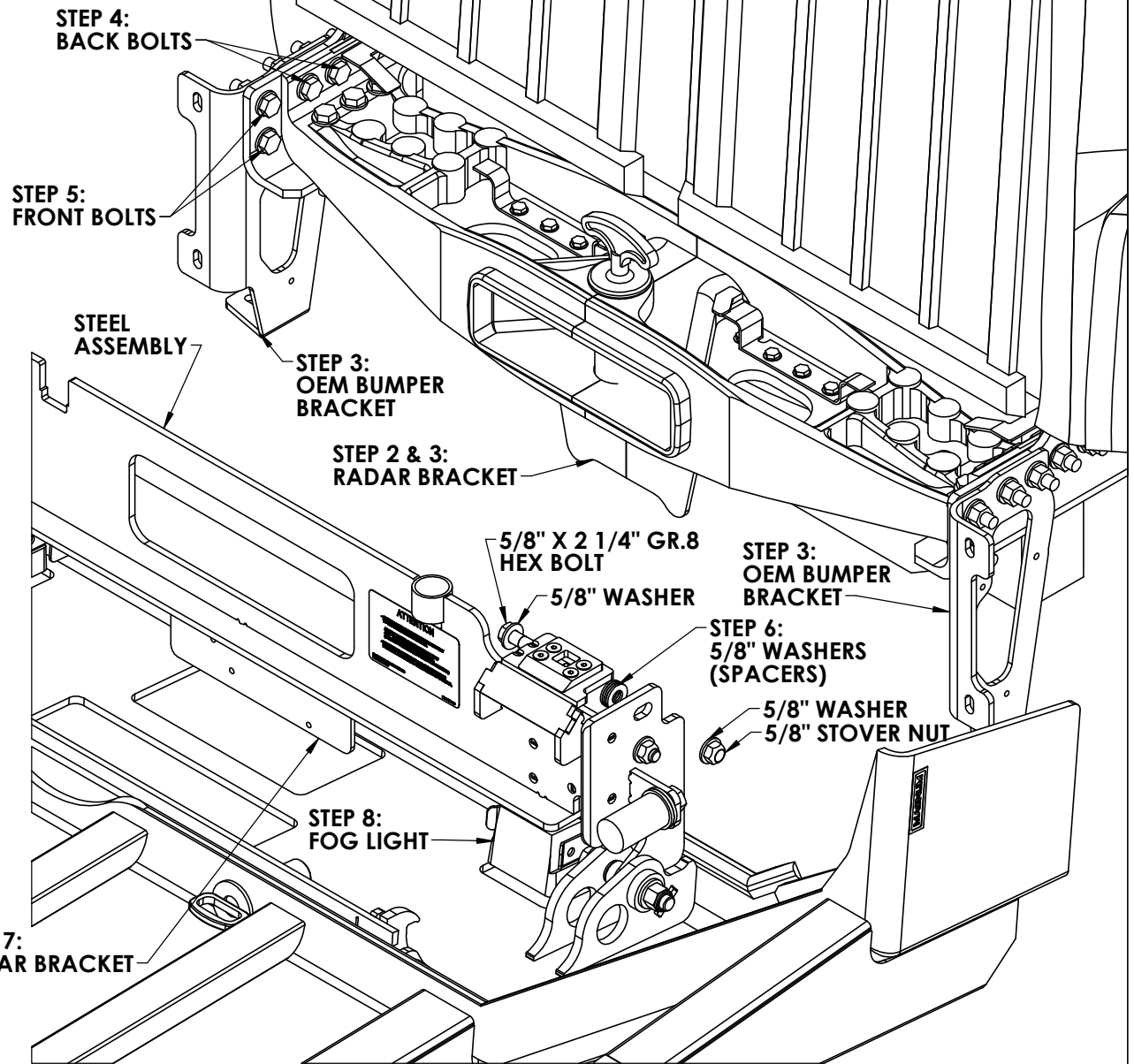

**NOTE:**  
IF EQUIPPED, RADAR MUST BE REMOVED BEFORE BUMPER INSTALLATION.  
  
RADAR MUST BE RE-CALIBRATED AFTER BUMPER INSTALLATION. CALIBRATION CAN ONLY BE DONE BY AUTHORIZED PERSONNEL

<b>MAGNUM TRAILER &amp; EQUIPMENT INC.</b>  	<b>FRACTIONS CHART</b>				UNLESS OTHERWISE SPECIFIED DIMENSIONS ARE IN INCHES TOLERANCES ARE: <b>FRACTIONS</b> <b>ANGLES</b> +/- 1/16"       +/- 1° .XX"            .XXX" +/- 0.03"      +/- 0.005"		SHEET NAME		TITLE			
	1/32 .03125	9/32 .28125	17/32 .53125	25/32 .78125			Sheet1		17279 ON 2021 WESTERN STAR 49X SBA (LOGGER)			
	1/16 .0625	5/16 .3125	9/16 .5625	13/16 .8125	CURRENT CUSTOMER		STOCK NUMBER		VENDOR NUMBER		WEIGHT - LB.	
	3/32 .09375	11/32 .34375	19/32 .59375	27/32 .84375	WO#		DRAWN BY		DRAWN DATE	CHECKED BY	CHECKED DATE	REV.
1/8 .125	3/8 .375	5/8 .625	7/8 .875	SCALE		MD		9/20/2021	LS	9/20/2021	B	
5/32 .15625	13/32 .40625	21/32 .65625	29/32 .90625	1:8		MD		DRAWING NUMBER		NUMBER OF SHEETS		
3/16 .1875	7/16 .4375	11/16 .6875	15/16 .9375	DIMENSIONS TO SHARP POINTS		AA-59158				2		
7/32 .21875	15/32 .46875	23/32 .71875	31/32 .96875									
1/4 .25	1/2 .5	3/4 .75										

### INSTALLING FOG LIGHT

1. ATTACH FOG LIGHT TO THE ANGLE ALUMINUM BRACKET USING THE SUPPLIED HARDWARE AND OEM HARDWARE:

**SUPPLIED:**

- 3/8" X 1" GR.5 HEX BOLT (2)
- 3/8" GR.C STOVER NUT (2)
- 3/8" GR.2 FLAT WASHER (4)

**OEM HARDWARE:**

- M10 HEX BOLT (2)
- M10 WASHER (2)

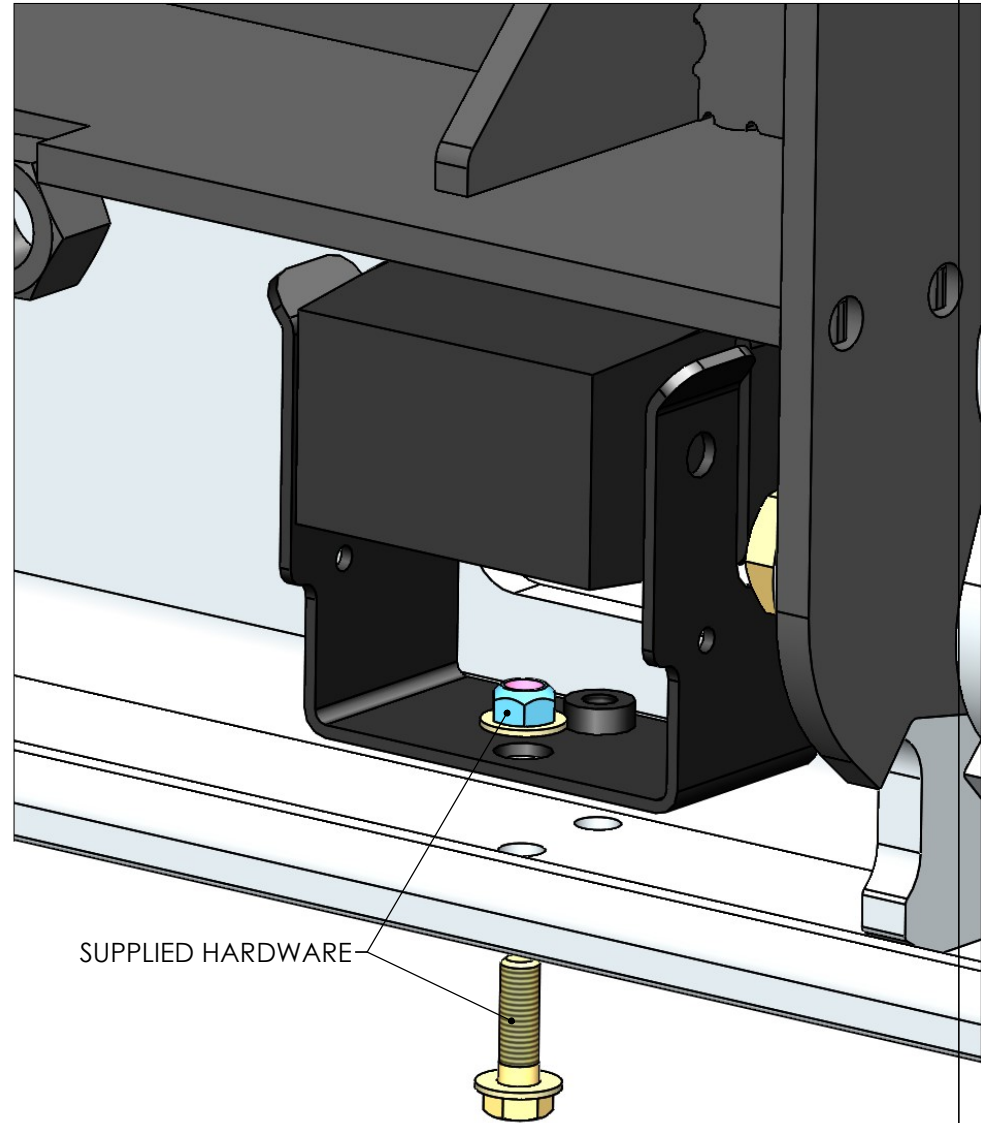

SUPPLIED HARDWARE

**MAGNUM TRAILER & EQUIPMENT INC.**



**FRACTIONS CHART**

1/32	.03125	9/32	.28125	17/32	.53125	25/32	.78125
1/16	.0625	5/16	.3125	9/16	.5625	13/16	.8125
3/32	.09375	11/32	.34375	19/32	.59375	27/32	.84375
1/8	.125	3/8	.375	5/8	.625	7/8	.875
5/32	.15625	13/32	.40625	21/32	.65625	29/32	.90625
3/16	.1875	7/16	.4375	11/16	.6875	15/16	.9375
7/32	.21875	15/32	.46875	23/32	.71875	31/32	.96875
1/4	.25	1/2	.5	3/4	.75		

UNLESS OTHERWISE SPECIFIED DIMENSIONS ARE IN INCHES  
TOLERANCES ARE:  
FRACTIONS ANGLES  
+/- 1/16" +/- 1°  
.XX" .XXX"  
+/- 0.03" +/- 0.005"

DIMENSIONS TO SHARP POINTS

SHEET NAME <b>FOG LIGHT</b>		TITLE <b>17279 ON 2021 WESTERN STAR 49X SBA (LOGGER)</b>			
CURRENT CUSTOMER		STOCK NUMBER		VENDOR NUMBER	
WO#		DRAWN DATE 9/20/2021		CHECKED DATE 9/20/2021	
SCALE 2:3		DRAWN BY MD		CHECKED BY LS	
		MODELLER MD		REVISION B	
		DRAWING NUMBER <b>AA-59158</b>		WEIGHT - LB. 316.	
				NUMBER OF SHEETS 2	