

**MAGNUM TRAILER & EQUIPMENT INC.**

FRACTIONS CHART							
1/32	.03125	9/32	.28125	17/32	.53125	25/32	.78125
1/16	.0625	5/16	.3125	9/16	.5625	13/16	.8125
3/32	.09375	11/32	.34375	19/32	.59375	27/32	.84375
1/8	.125	3/8	.375	5/8	.625	7/8	.875
5/32	.15625	13/32	.40625	21/32	.65625	29/32	.90625
3/16	.1875	7/16	.4375	11/16	.6875	15/16	.9375
7/32	.21875	15/32	.46875	23/32	.71875	31/32	.96875
1/4	.25	1/2	.5	3/4	.75		

UNLESS OTHERWISE SPECIFIED DIMENSIONS ARE IN INCHES TOLERANCES ARE:

FRACTIONS	ANGLES
± 1/16"	± 1°
.XX"	.XXX"
± 0.03"	± 0.005"

DIMENSIONS TO SHARP POINTS

SHEET NAME	BUMPER INSTALL		
CURRENT CUSTOMER	WO#	SCALE	1:8

TITLE				17274 ON 2021 KENWORTH T680			
STOCK NUMBER		VENDOR NUMBER		WEIGHT - LB.		365	
DRAWN BY	DRAWN DATE	CHECKED BY	CHECKED DATE	REV.			
DP	6/23/2021	LS	6/28/2021	C			
MODELLER		DRAWING NUMBER		NUMBER OF SHEETS			
DP		AA-58470		3			

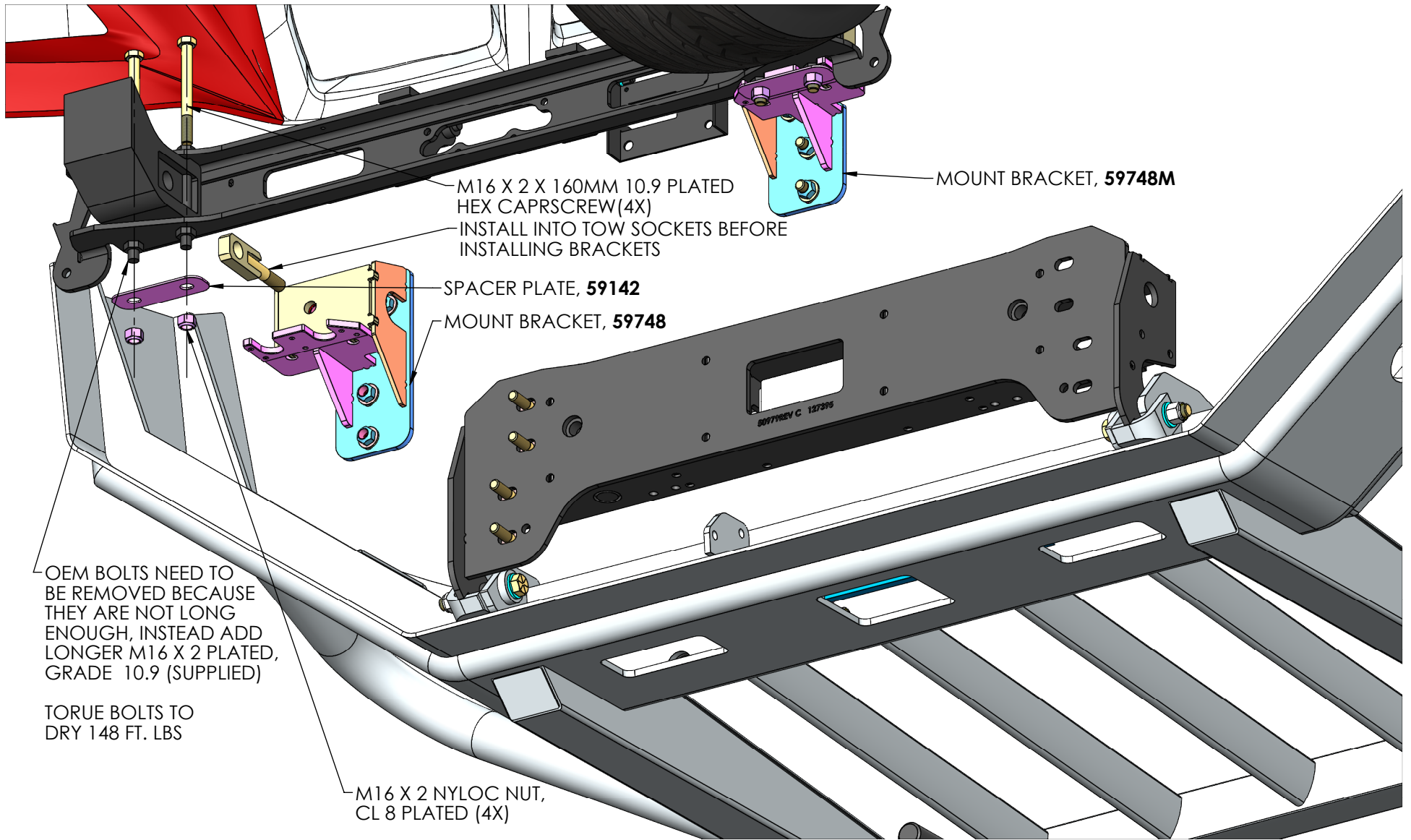

**MAGNUM TRAILER & EQUIPMENT INC.**



**FRACTIONS CHART**

1/32	.03125	9/32	.28125	17/32	.53125	25/32	.78125
1/16	.0625	5/16	.3125	9/16	.5625	13/16	.8125
3/32	.09375	11/32	.34375	19/32	.59375	27/32	.84375
1/8	.125	3/8	.375	5/8	.625	7/8	.875
5/32	.15625	13/32	.40625	21/32	.65625	29/32	.90625
3/16	.1875	7/16	.4375	11/16	.6875	15/16	.9375
7/32	.21875	15/32	.46875	23/32	.71875	31/32	.96875
1/4	.25	1/2	.5	3/4	.75		

UNLESS OTHERWISE SPECIFIED DIMENSIONS ARE IN INCHES TOLERANCES ARE:

FRACTIONS	ANGLES
± 1/16"	± 1°
.XX"	.XXX"
± 0.03"	± 0.005"

DIMENSIONS TO SHARP POINTS

SHEET NAME  
**BRACKET INSTALL**

CURRENT CUSTOMER

**WO#**

SCALE  
1:12

TITLE  
**17274 ON 2021 KENWORTH T680**

STOCK NUMBER

DRAWN BY  
DP

MODELLER  
DP

VENDOR NUMBER

DRAWN DATE  
6/23/2021

DRAWING NUMBER  
**AA-58470**

CHECKED BY  
LS

CHECKED DATE  
6/28/2021

NUMBER OF SHEETS  
3

WEIGHT - LB.

365

REV.  
C

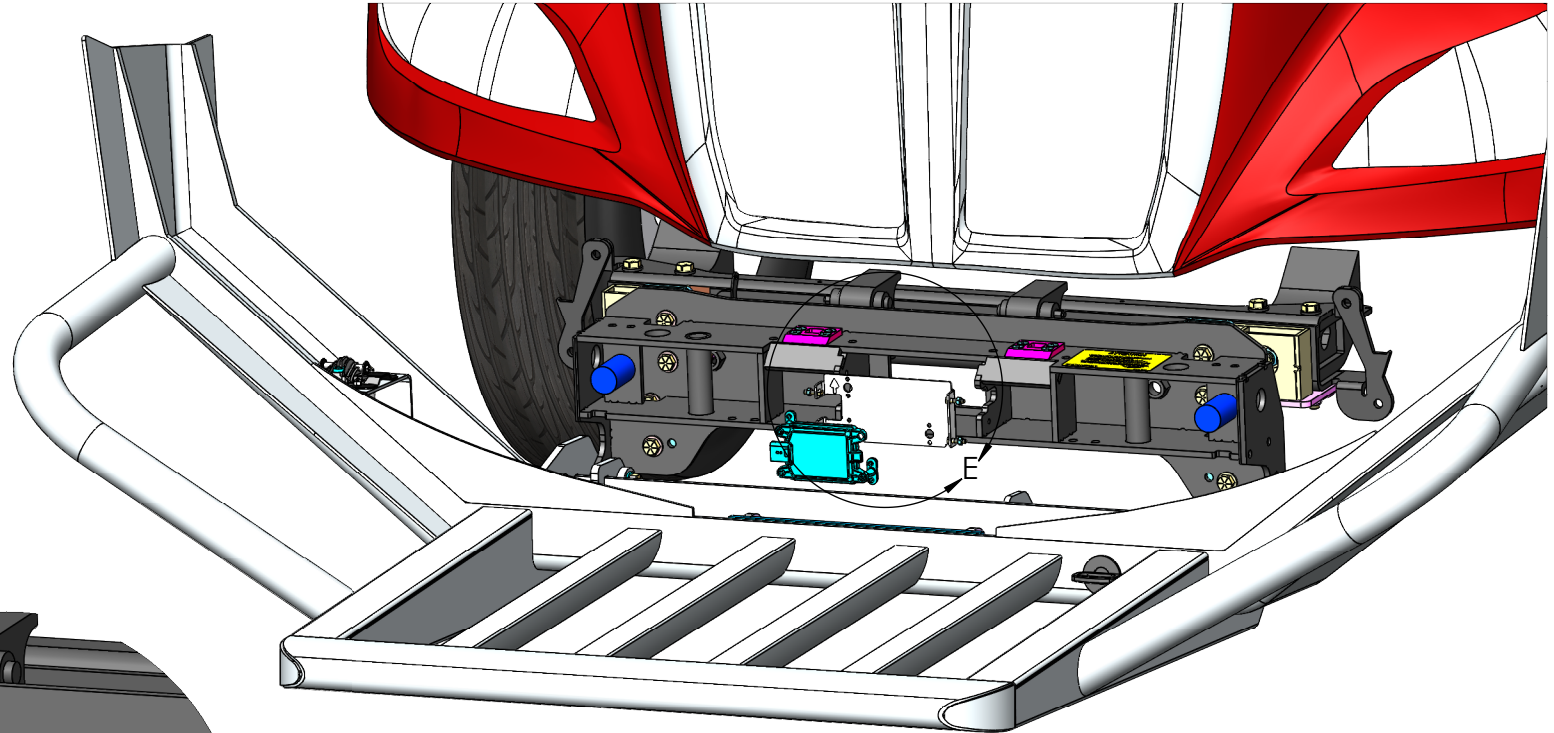

**STEP (2)**  
 RECONNECT RADAR TO THE TRUCK (USE BRACKET SLOT TO FISH RADAR CABLE)

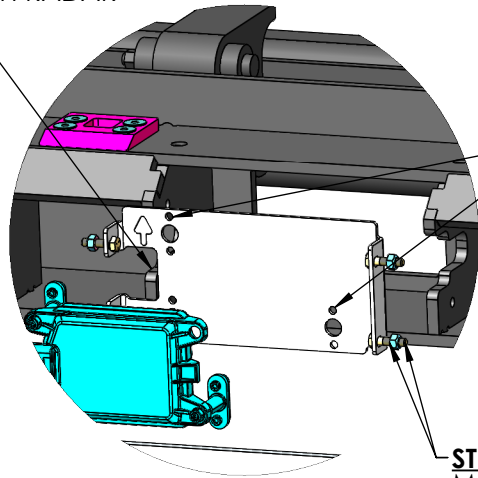

**DETAIL E**  
**SCALE 1 : 6**

**STEP (1)**  
 INSTALL RADAR INTO RADAR BRACKET SUPPLIED REUSING ORIGINAL ADJUSTABLE STAND-OFF AND FASTENERS

**STEP (3)**  
 MOUNT RADAR BRACKET WITH RADAR INSTALLED ON IT USING 1/4" NC X 1" GR. 5 AND GR.C STOVER NUTS (SUPPLIED) 4 PLACES

**NOTE:**  
 IF EQUIPED, RADAR MUST BE REMOVED BEFORE BUMPER INSTALLATION  
 RADAR MUST BE RE-CALIBRATED AFTER BUMPER INSTALLATION.  
 CALIBRATION CAN ONLY BE DONE BY AUTHORIZED PERSONNEL

<b>MAGNUM TRAILER &amp; EQUIPMENT INC.</b> 	<b>FRACTIONS CHART</b>				<b>UNLESS OTHERWISE SPECIFIED DIMENSIONS ARE IN INCHES TOLERANCES ARE:</b>		<b>SHEET NAME</b> RADAR INSTALL		<b>TITLE</b> 17274 ON 2021 KENWORTH T680						
	1/32 .03125	9/32 .28125	17/32 .53125	25/32 .78125	<b>FRACTIONS</b>		<b>ANGLES</b>		<b>CURRENT CUSTOMER</b>		<b>STOCK NUMBER</b>		<b>VENDOR NUMBER</b>		
	1/16 .0625	5/16 .3125	9/16 .5625	13/16 .8125	<b>+/- 1/16"</b>		<b>+/- 1°</b>		<b>WEIGHT - LB.</b>		<b>365</b>				
	3/32 .09375	11/32 .34375	19/32 .59375	27/32 .84375	<b>.XX"</b>		<b>.XXX"</b>		<b>SCALE</b>		<b>1:12</b>				
1/8 .125	3/8 .375	5/8 .625	7/8 .875	<b>+/- 0.03"</b>		<b>+/- 0.005"</b>		<b>WO#</b>		<b>DP</b>					
5/32 .15625	13/32 .40625	21/32 .65625	29/32 .90625	<b>DIMENSIONS TO SHARP POINTS</b>				<b>SCALE</b>		<b>1:12</b>					
3/16 .1875	7/16 .4375	11/16 .6875	15/16 .9375					<b>SCALE</b>		<b>1:12</b>					
7/32 .21875	15/32 .46875	23/32 .71875	31/32 .96875					<b>SCALE</b>		<b>1:12</b>					
1/4 .25	1/2 .5	3/4 .75						<b>SCALE</b>		<b>1:12</b>					
								<b>MODELLER</b>		<b>DP</b>		<b>DRAWING NUMBER</b>		<b>AA-58470</b>	
								<b>SCALE</b>		<b>1:12</b>		<b>NUMBER OF SHEETS</b>		<b>3</b>	