

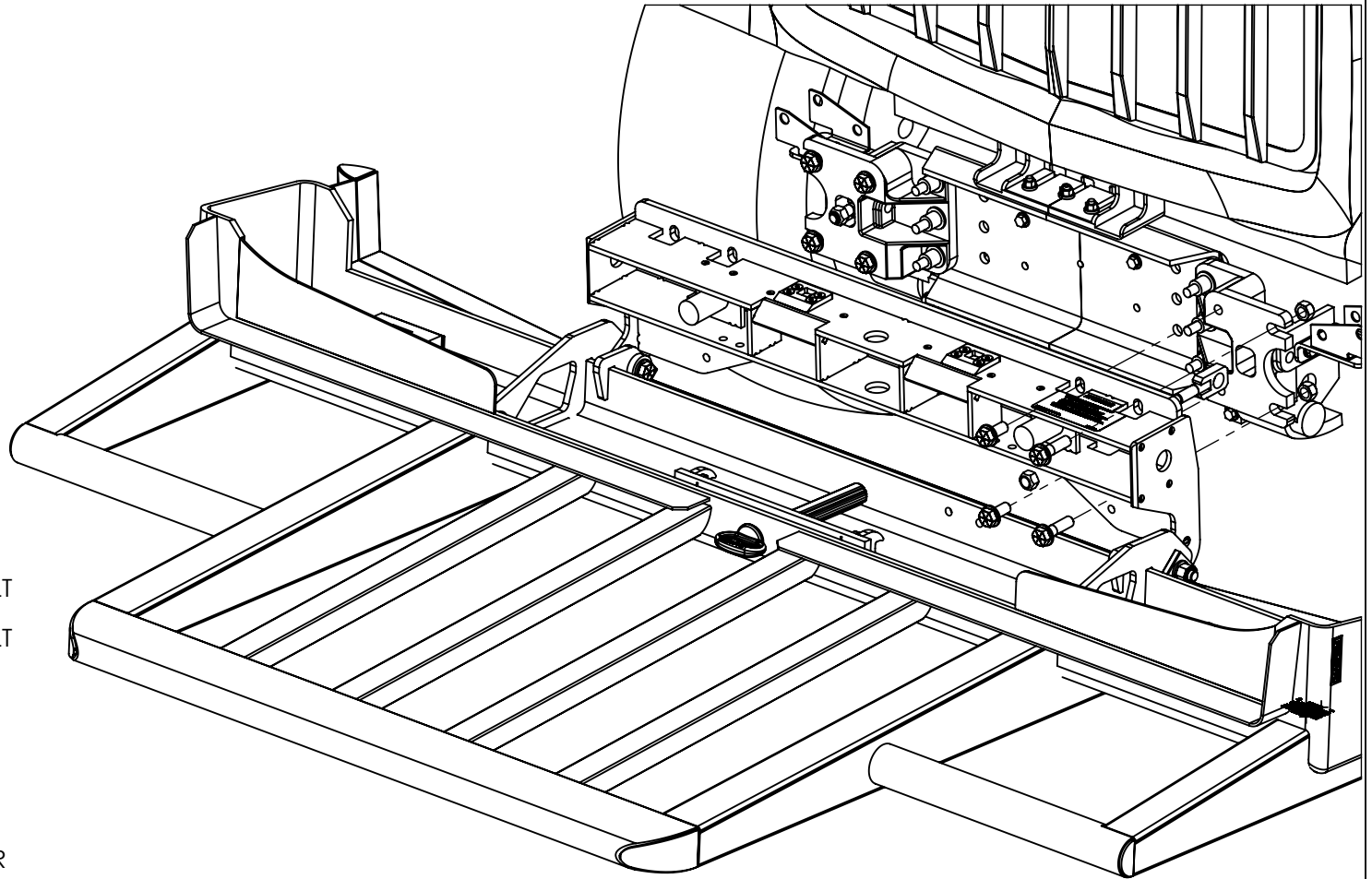

INSTALLING 17277 ON INTERNATIONAL HX520

1. REMOVE FOG LIGHTS FROM OEM BUMPER (KEEP HARDWARE).
2. REMOVE OEM BUMPER FROM TRUCK (KEEP HARDWARE).
3. INSERT THE TWO TOW MOUNT ASSEMBLIES (58922) INTO THE TRUCKS TOW RECIEVERS.
4. SECURE THE TOW MOUNTS IN PLACE USING THE FACTORY TOW PINS.
5. ATTACH THE 17277 BUMPER TO THE TRUCK USING THE OEM HARDWARE IN ITS ORIGINAL CONFIGURATION.
 HARDWARE:
 3/4" UNF X 1 3/4" GR.8 HEX BOLT (4) (TORQUE TO 180 FT-LBS)
 3/4" UNF X 2 3/4" GR.8 HEX BOLT (4) (TORQUE TO 180 FT-LBS)
 3/4" GR.8 WASHERS (8)
 3/4" FLANGE NUTS(4)
6. SECURE TOW MOUNTS USING SUPPLIED 3/4" GR.C STOVER NUTS (TORQUE TO 200 FT-LBS).
7. INSTALL FOG LIGHTS IN BUMPER USING THE OEM HARDWARE.
 HARDWARE:
 M8 X 25 CARRIAGE BOLT (2)
 M8 LOCK WASHER(2)
 M8 FLAT WASHER (2)
 M8 HEX NUT (2)
8. INSTALLATION IS COMPLETE.



MAGNUM TRAILER & EQUIPMENT INC. 	FRACTIONS CHART								UNLESS OTHERWISE SPECIFIED DIMENSIONS ARE IN INCHES TOLERANCES ARE: FRACTIONS ANGLES +/- 1/16" +/- 1° .XX" .XXX" +/- 0.03" +/- 0.005"				SHEET NAME INSTALL		TITLE 17277 ON INTERNATIONAL HX520 SFA					
									CURRENT CUSTOMER		STOCK NUMBER			VENDOR NUMBER			WEIGHT - LB. 357.			
									WO#		DRAWN BY MD		DRAWN DATE 7/20/2021		CHECKED BY LS		CHECKED DATE 8/04/2021		REV.	
									SCALE 1:12		MODELLER MD			DRAWING NUMBER AA-58899			NUMBER OF SHEETS 1			
DIMENSIONS TO SHARP POINTS																				

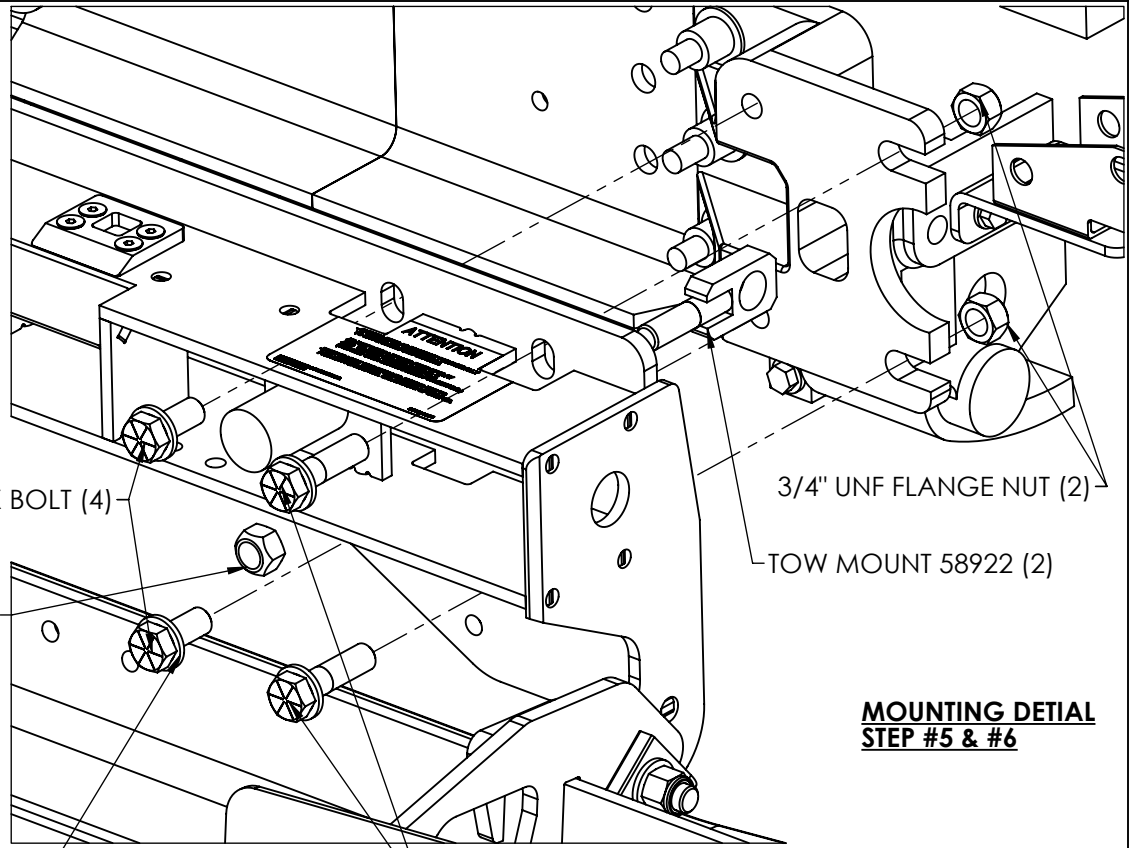

3/4" UNF X 1 3/4" GR.8 HEX BOLT (4)

3/4" UNF FLANGE NUT (2)

3/4" UNC GR.C STOVER NUT (2)

TOW MOUNT 58922 (2)

**MOUNTING DETAIL
STEP #5 & #6**

3/4" GR.8 WASHER (8)

3/4" UNF X 2 3/4" GR.8 HEX BOLT (4)

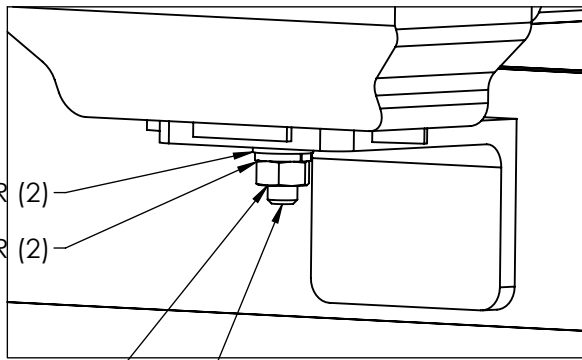

M8 LOCK WASHER (2)

M8 FLAT WASHER (2)

M8 HEX NUT (2)

M8 X 25 CARRIAGE BOLT (2)

**FOG LIGHT DETAIL
STEP #7**

**MAGNUM TRAILER
&
EQUIPMENT INC.**



FRACTIONS CHART

1/32	.03125	9/32	.28125	17/32	.53125	25/32	.78125
1/16	.0625	5/16	.3125	9/16	.5625	13/16	.8125
3/32	.09375	11/32	.34375	19/32	.59375	27/32	.84375
1/8	.125	3/8	.375	5/8	.625	7/8	.875
5/32	.15625	13/32	.40625	21/32	.65625	29/32	.90625
3/16	.1875	7/16	.4375	11/16	.6875	15/16	.9375
7/32	.21875	15/32	.46875	23/32	.71875	31/32	.96875
1/4	.25	1/2	.5	3/4	.75		

UNLESS OTHERWISE SPECIFIED
DIMENSIONS ARE IN INCHES
TOLERANCES ARE:

FRACTIONS	ANGLES
±.001"	±.1°
±.005"	±.5°
±.010"	±1.0°
±.015"	±1.5°
±.030"	±3.0°
±.063"	±6.3°
±.125"	±12.5°
±.250"	±25.0°
±.500"	±50.0°
±1.000"	±100.0°
±.001"	±.1°
±.005"	±.5°
±.010"	±1.0°
±.015"	±1.5°
±.030"	±3.0°
±.063"	±6.3°
±.125"	±12.5°
±.250"	±25.0°
±.500"	±50.0°
±1.000"	±100.0°

DIMENSIONS TO SHARP POINTS

SHEET NAME
INSTALL 2

TITLE
17277 ON INTERNATIONAL HX520 SFA

CURRENT CUSTOMER	STOCK NUMBER	VENDOR NUMBER	WEIGHT - LB.
			357.
WO#	DRAWN BY MD	DRAWN DATE 7/20/2021	CHECKED BY LS
SCALE 1:5	MODELLER MD	DRAWING NUMBER AA-58899	CHECKED DATE 8/04/2021
			REV. NUMBER OF SHEETS 1