

**INSTALLING MG-100/200/300**

- 1) OPEN HOOD AND REMOVE FACTORY TOW PINS FROM TRUCK
- 2) INSERT MOUNT BRACKETS INTO THE TOW SOCKETS (TOW PLATES SHOULD BE ON THE INSIDE OF THE BUMPER)
- 3) SLIDE FACTORY TOW PINS OR EQUIVALENT BOLT THROUGH THE TRUCK FRAME AND MOUNT BRACKETS.
- 4) TIGHTEN THE 5/8" NF STOVER NUT TO 128 FT-LBS TO SECURE THE BRACKETS IN PLACE
- 5) ATTACH THE MG-100 TO THE MOUNT BRACKETS USING THE TOP TWO ROWS OF SLOTS. SHIMS SHOULD BE PLACED BETWEEN THE GUARD AND THE MOUNT BRACKETS.  
HARDWARE: 5/8" NC X 1 3/4" BOLT, 5/8" WASHER & 5/8" STOVER NUT  
TIGHTEN TO 159 FT-LBS (6 PLACES)
- 6) THE GUARD IS NOW INSTALLED. THE HOOD CAN NOW BE CLOSED. REFER TO DRAWING #54268 FOR INSTALLING THE MG-200T/300T IF REQUIRED.

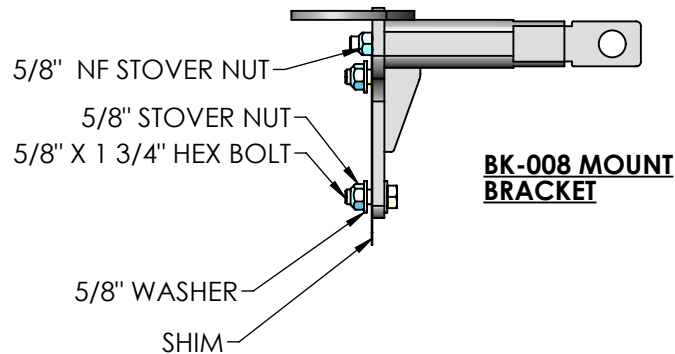
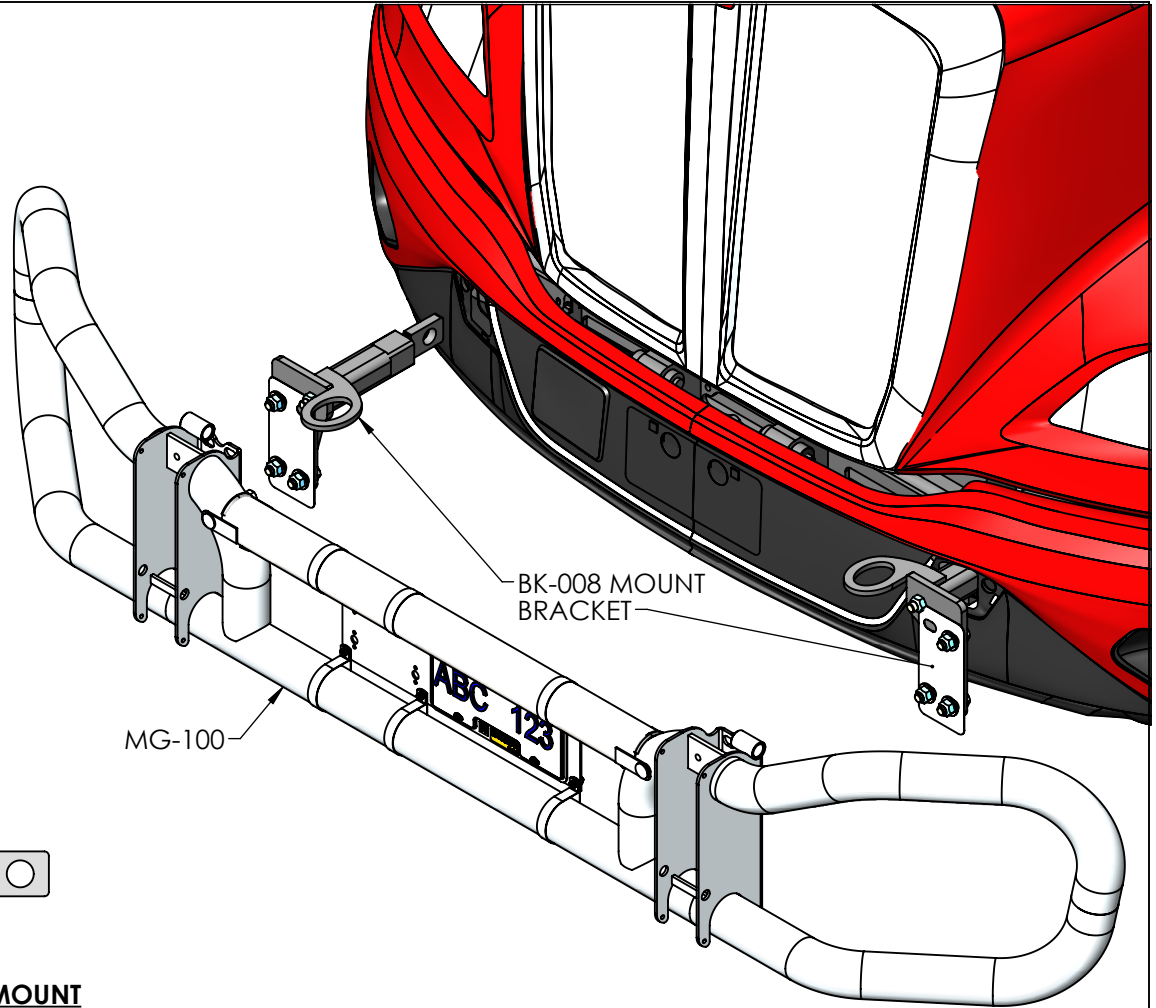

**BK-008 MOUNT BRACKET**

**MAGNUM TRAILER & EQUIPMENT INC.**



**FRACTIONS CHART**

1/32	.03125	9/32	.28125	17/32	.53125	25/32	.78125
1/16	.0625	5/16	.3125	9/16	.5625	13/16	.8125
3/32	.09375	11/32	.34375	19/32	.59375	27/32	.84375
1/8	.125	3/8	.375	5/8	.625	7/8	.875
5/32	.15625	13/32	.40625	21/32	.65625	29/32	.90625
3/16	.1875	7/16	.4375	11/16	.6875	15/16	.9375
7/32	.21875	15/32	.46875	23/32	.71875	31/32	.96875
1/4	.25	1/2	.5	3/4	.75		

UNLESS OTHERWISE SPECIFIED DIMENSIONS ARE IN INCHES TOLERANCES ARE:

FRACTIONS	ANGLES
+/- 1/16"	+/- 1°
.XX"	.XXX"
+/- 0.03"	+/- 0.005"

DIMENSIONS TO SHARP POINTS

SHEET NAME	TITLE			
Sheet1	<b>MG SERIES BUMPER ON 2021 KENWORTH T-680</b>			
CURRENT CUSTOMER	STOCK NUMBER	VENDOR NUMBER	WEIGHT - LB.	
			91.8	
WO#	DRAWN BY	DRAWN DATE	CHECKED BY	CHECKED DATE
	MD	6/7/2021	LS	6/21/2021
SCALE	MODELLER	DRAWING NUMBER		NUMBER OF SHEETS
1:12	MD	<b>AA-58591</b>		1