

INSTALL MOUNT ASSEMBLY  
(2 SUPPLIED) INTO TRUCK FRAME  
**BEFORE** INSTALLING BUMPER  
- USE PINS FROM FACTORY  
TOW YOKES

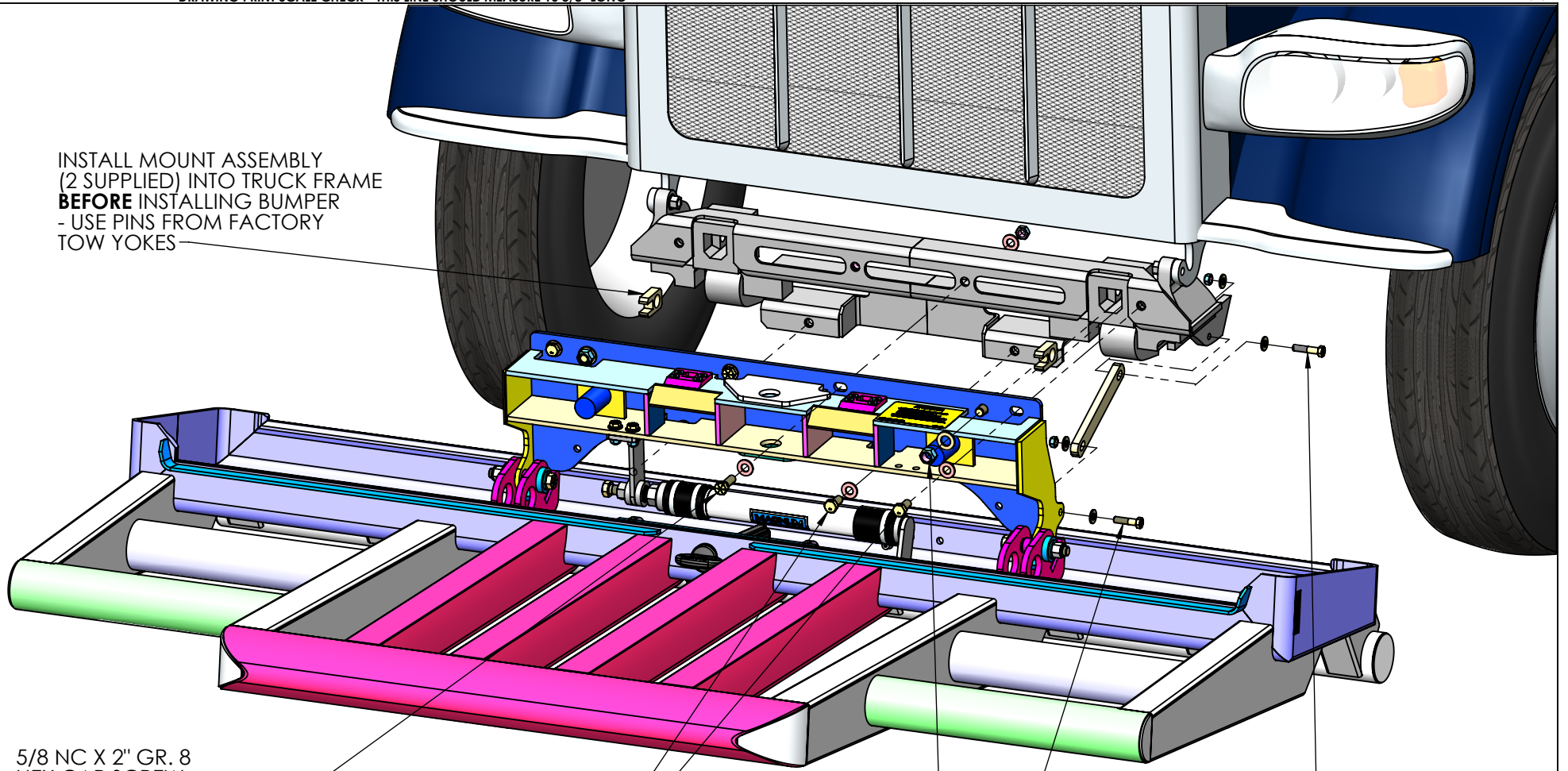

5/8 NC X 2" GR. 8  
HEX CAP SCREW,  
WASHERS & GR. C  
STOVER NUT  
(SUPPLIED)  
TYP (2)

M16 X 2 X 35 HEX CAP SCREWS  
CL 10.9 & METRIC WASHER  
(SUPPLIED) TYP (4)

3/4 NC STOVER NUT GR. C  
& WASHER (SUPPLIED)  
TYP (2)

1/2 NC X 2 1/2" GR. 8  
HEX CAP SCREW,  
WASHERS & GR. C  
STOVER NUT  
(SUPPLIED)  
TYP (2)

1/2 NC X 2 1/2" GR. 8  
HEX CAP SCREW,  
WASHERS & GR. C  
STOVER NUT  
(SUPPLIED) TYP (2)

**MAGNUM TRAILER  
&  
EQUIPMENT INC.**



**FRACTIONS CHART**

1/32	.03125	9/32	.28125	17/32	.53125	25/32	.78125
1/16	.0625	5/16	.3125	9/16	.5625	13/16	.8125
3/32	.09375	11/32	.34375	19/32	.59375	27/32	.84375
1/8	.125	3/8	.375	5/8	.625	7/8	.875
5/32	.15625	13/32	.40625	21/32	.65625	29/32	.90625
3/16	.1875	7/16	.4375	11/16	.6875	15/16	.9375
7/32	.21875	15/32	.46875	23/32	.71875	31/32	.96875
1/4	.25	1/2	.5	3/4	.75		

UNLESS OTHERWISE SPECIFIED  
DIMENSIONS ARE IN INCHES  
TOLERANCES ARE:

FRACTIONS	ANGLES
+/- 1/16"	+/- 1°
.XX"	.XXX"
+/- 0.03"	+/- 0.005"

**DIMENSIONS TO SHARP POINTS**

SHEET NAME

Sheet1

CURRENT CUSTOMER

**WO#**

SCALE

1:12

TITLE

**17178 BUMPER ON 2007 PETERBILT 388/389**

STOCK NUMBER

VENDOR NUMBER

WEIGHT - LB.

445.

DRAWN BY

DRAWN DATE

CHECKED BY

CHECKED DATE

REV.

BNS

6/5/2014

LS

5/27/2021

A

MODELLER

DRAWING NUMBER

NUMBER OF SHEETS

BNS

**AA-34847**

1