

DO NOT REMOVE

3/4" NC X 3" GR. 8  
2 SAE WASHERS &  
GR.C STOVER NUT  
TYP (2)  
(SUPPLIED)

3/4" SAE WASHER &  
3/4" NC GR. C  
STOVER NUT  
TYP (2) (SUPPLIED)

REMOVE FASTENERS

USE THIS HOLE FOR  
15L MODEL

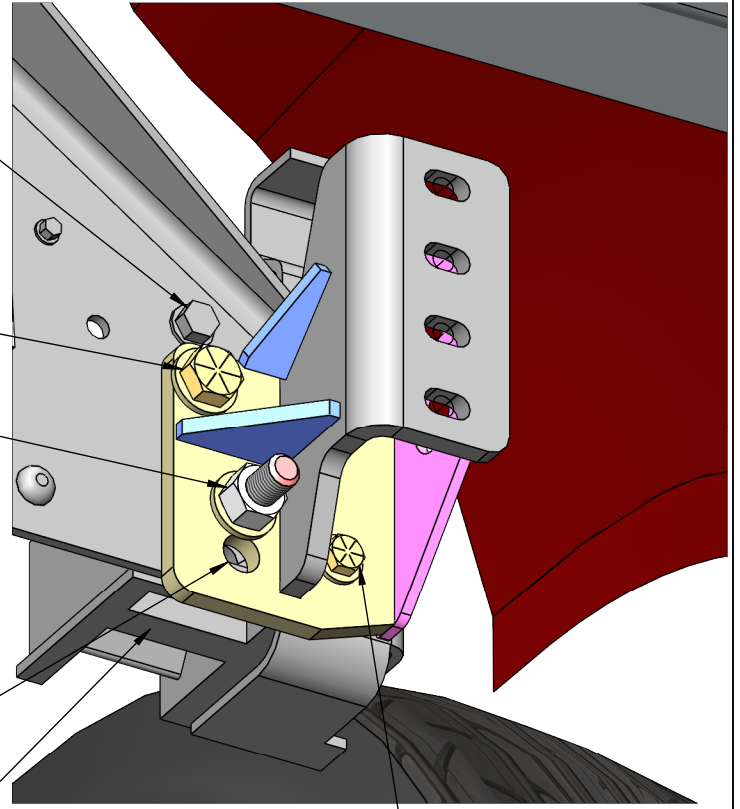

INSTALL THREADED PLATE &  
REDI-ROD BEFORE INSTALLING  
BRACKET TYP (2) (SUPPLIED)

1/2" NC X 2 1/4" GR. 8  
2 SAE WASHERS &  
GR.C STOVER NUT  
TYP (4) (SUPPLIED)

NOTE:  
13L CONFIGURATION SHOWN

**MAGNUM TRAILER  
&  
EQUIPMENT INC.**



**FRACTIONS CHART**

1/32	.03125	9/32	.28125	17/32	.53125	25/32	.78125
1/16	.0625	5/16	.3125	9/16	.5625	13/16	.8125
3/32	.09375	11/32	.34375	19/32	.59375	27/32	.84375
1/8	.125	3/8	.375	5/8	.625	7/8	.875
5/32	.15625	13/32	.40625	21/32	.65625	29/32	.90625
3/16	.1875	7/16	.4375	11/16	.6875	15/16	.9375
7/32	.21875	15/32	.46875	23/32	.71875	31/32	.96875
1/4	.25	1/2	.5	3/4	.75		

UNLESS OTHERWISE SPECIFIED  
DIMENSIONS ARE IN INCHES  
TOLERANCES ARE:

FRACTIONS	ANGLES
+/- 1/16"	+/- 1°
.XX"	.XXX"
+/- 0.03"	+/- 0.005"

DIMENSIONS TO SHARP POINTS

SHEET NAME		TITLE			
Sheet1		17272 MOO BUMPER ASSEMBLY ON 2008 INTERNATIONAL PROSTAR			
CURRENT CUSTOMER	STOCK NUMBER	VENDOR NUMBER		WEIGHT - LB.	
				391.	
WO#	DRAWN BY	DRAWN DATE	CHECKED BY	CHECKED DATE	REV.
	DP	11/23/2020	MD	12/14/2020	
SCALE	DRAWING NUMBER		NUMBER OF SHEETS		
1:4	AA-57275		3		

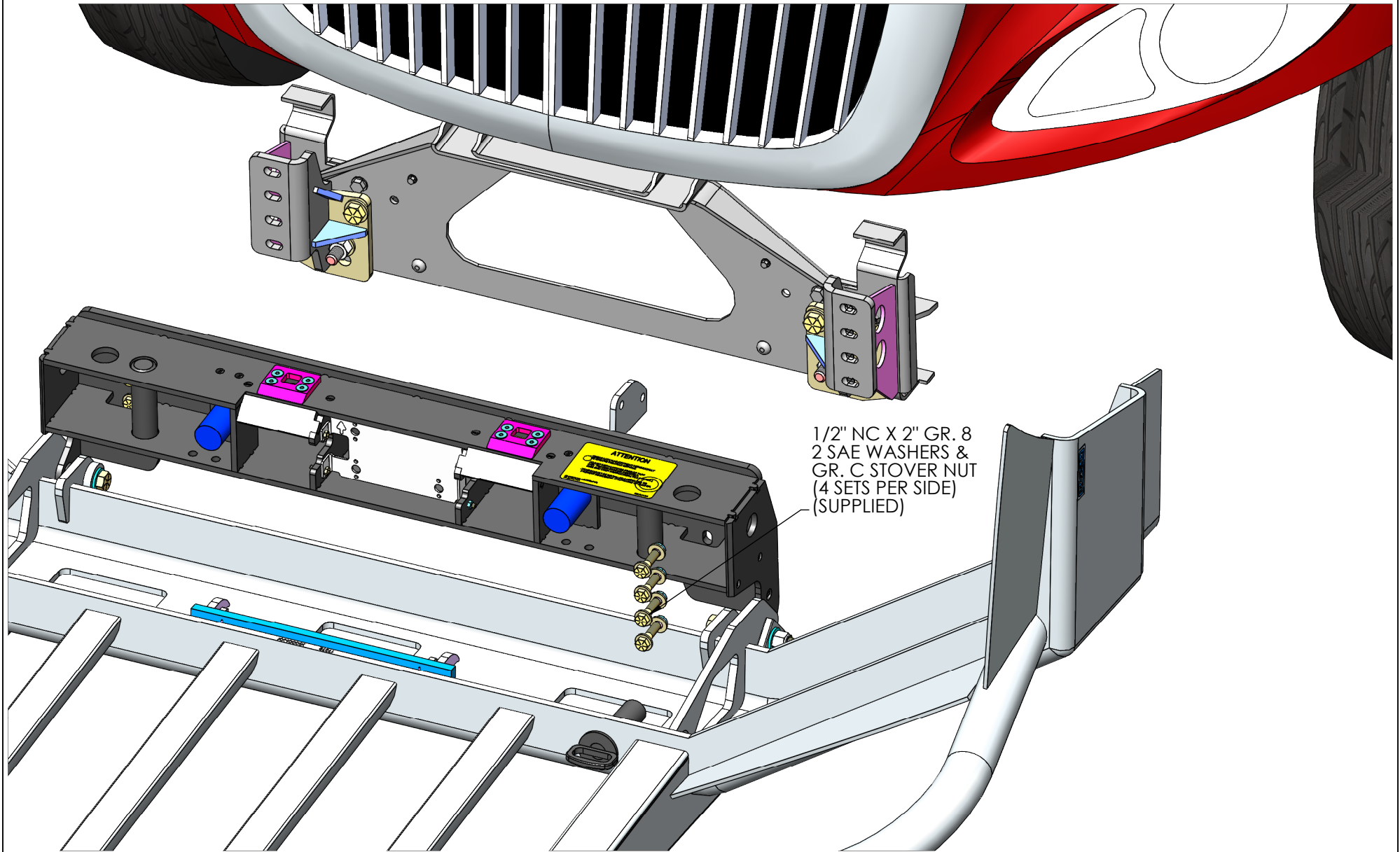

**MAGNUM TRAILER & EQUIPMENT INC.**



**FRACTIONS CHART**

1/32	.03125	9/32	.28125	17/32	.53125	25/32	.78125
1/16	.0625	5/16	.3125	9/16	.5625	13/16	.8125
3/32	.09375	11/32	.34375	19/32	.59375	27/32	.84375
1/8	.125	3/8	.375	5/8	.625	7/8	.875
5/32	.15625	13/32	.40625	21/32	.65625	29/32	.90625
3/16	.1875	7/16	.4375	11/16	.6875	15/16	.9375
7/32	.21875	15/32	.46875	23/32	.71875	31/32	.96875
1/4	.25	1/2	.5	3/4	.75		

UNLESS OTHERWISE SPECIFIED DIMENSIONS ARE IN INCHES TOLERANCES ARE:

FRACTIONS	ANGLES
+/- 1/16"	+/- 1°
.XX"	.XXX"
+/- 0.03"	+/- 0.005"

DIMENSIONS TO SHARP POINTS

SHEET NAME		TITLE			
Sheet2		17272 MOO BUMPER ASSEMBLY ON 2008 INTERNATIONAL PROSTAR			
CURRENT CUSTOMER		STOCK NUMBER		VENDOR NUMBER	
				WEIGHT - LB. 391.	
DRAWN BY		DRAWN DATE		CHECKED BY	
DP		11/23/2020		MD	
CHECKED DATE		12/14/2020		REV.	
WO#		DRAWING NUMBER			
		AA-57275			
SCALE		1:8		NUMBER OF SHEETS	
				3	

**USE ONLY FASTENERS AND GRADES SPECIFIED**

**STEP (2):**  
RECONNECT RADAR TO THE TRUCK  
(USE BRACKET SLOT TO FISH RADAR  
CABLE)

**STEP (1):**  
INSTALL RADAR INTO RADAR  
BRACKET SUPPLIED REUSING  
ORIGINAL ADJUSTABLE STAND-OFF  
AND FASTENERS

**STEP (3):**  
MOUNT RADAR BRACKET  
WITH RADAR INSTALLED  
ON IT USING 1/4" NC X 3/4"  
GR. 5 AND GR. C STOVER  
NUTS (SUPPLIED)(4) PLACES

DETAIL A  
SCALE 1 : 5

**NOTE:**  
IF EQUIPED, RADAR MUST BE REMOVED BEFORE BUMPER INSTALLATION.  
RADAR MUST BE ALIGNED AND RE-CALIBRATED AFTER BUMPER INSTALLATION.  
ALIGNMENT AND CALIBRATION CAN ONLY BE DONE BY AUTHORIZED PERSONNEL.

<b>MAGNUM TRAILER &amp; EQUIPMENT INC.</b> 	<b>FRACTIONS CHART</b>				UNLESS OTHERWISE SPECIFIED DIMENSIONS ARE IN INCHES TOLERANCES ARE: <b>FRACTIONS</b> <b>ANGLES</b> +/- 1/16"    +/- 1° .XX"    .XXX" +/- 0.03"    +/- 0.005"	SHEET NAME		TITLE					
	1/32 .03125		9/32 .28125			RADAR INSTALL		17272 MOO BUMPER ASSEMBLY ON 2008 INTERNATIONAL PROSTAR					
	1/16 .0625		5/16 .3125			CURRENT CUSTOMER		STOCK NUMBER		VENDOR NUMBER		WEIGHT - LB.	
	3/32 .09375		11/32 .34375			WO#		DRAWN BY		DRAWN DATE		CHECKED BY	CHECKED DATE
1/8 .125		3/8 .375		DIMENSIONS TO SHARP POINTS		DP		11/23/2020		MD		12/14/2020	
5/32 .15625		13/32 .40625				SCALE		1:8		MODELLER		DRAWING NUMBER	
3/16 .1875		7/16 .4375								DP		AA-57275	
7/32 .21875		15/32 .46875										NUMBER OF SHEETS	
1/4 .25		1/2 .5										3	