

MAGNUM TRAILER & EQUIPMENT INC.



FRACTIONS CHART

1/32	.03125	9/32	.28125	17/32	.53125	25/32	.78125
1/16	.0625	5/16	.3125	9/16	.5625	13/16	.8125
3/32	.09375	11/32	.34375	19/32	.59375	27/32	.84375
1/8	.125	3/8	.375	5/8	.625	7/8	.875
5/32	.15625	13/32	.40625	21/32	.65625	29/32	.90625
3/16	.1875	7/16	.4375	11/16	.6875	15/16	.9375
7/32	.21875	15/32	.46875	23/32	.71875	31/32	.96875
1/4	.25	1/2	.5	3/4	.75		

UNLESS OTHERWISE SPECIFIED DIMENSIONS ARE IN INCHES TOLERANCES ARE:

FRACTIONS ANGLES
+/- 1/16" +/- 1deg

DIMENSIONS TO SHARP POINTS

SHEET NAME
BRACKET INSTALL

CURRENT CUSTOMER

WO#

SCALE

1:10

TITLE
17251 BUMPER ON VOLVO VNR

STOCK NUMBER

DRAWN BY
LS

MODELLER
LS

VENDOR NUMBER

DRAWN DATE
2/13/2018

DRAWING NUMBER
AA-49225

WEIGHT - LB.

REV.
B

NUMBER OF SHEETS
2

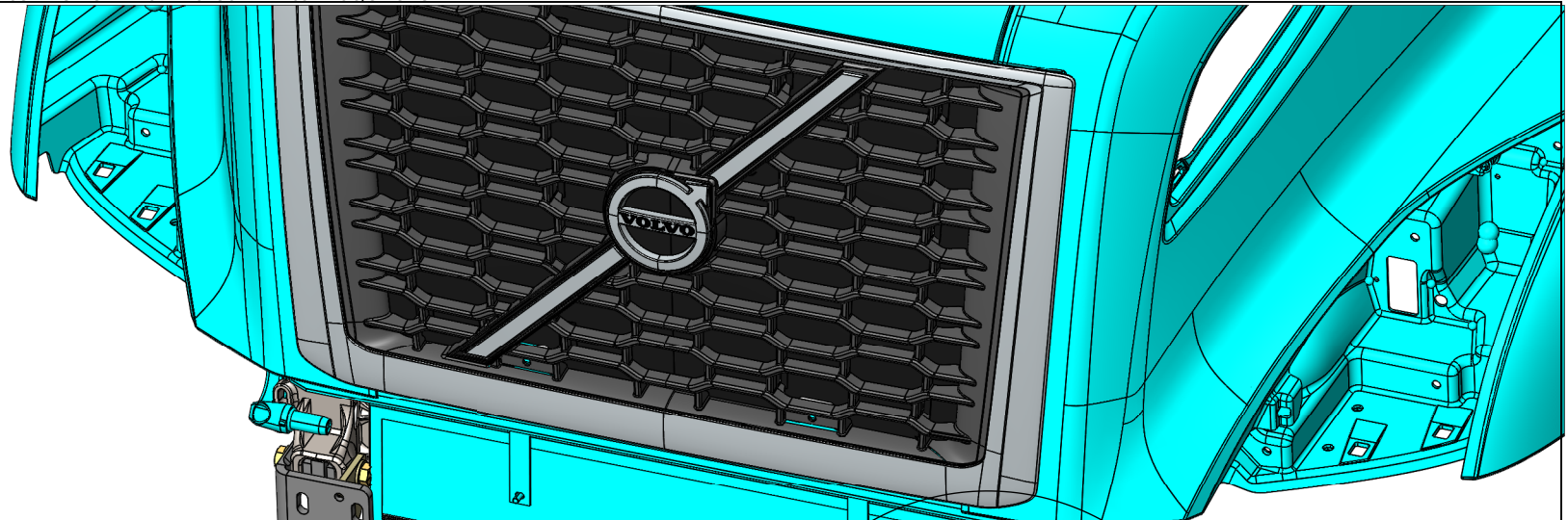

1/2" NC X 3-3/4" GR. 8 HEX BOLT,
GR. 8 WASHERS & STOVER NUT
(SUPPLIED) **(2) PLACES**

INNER MOUNT BRACKET
ASSEMBLY **16232**

48125M

1/2" STOVER
NUT

OUTER MOUNT
BRACKET ASEMBLY **48125**

16231

44377

3/4 NC X 1 3/4" GR. 8 CAPSCREW
& WASHER (SUPPLIED) **(6) PLACES**

DETAIL B
SCALE 1 : 6

**MAGNUM TRAILER
&
EQUIPMENT INC.**



FRACTIONS CHART

1/32	.03125	9/32	.28125	17/32	.53125	25/32	.78125
1/16	.0625	5/16	.3125	9/16	.5625	13/16	.8125
3/32	.09375	11/32	.34375	19/32	.59375	27/32	.84375
1/8	.125	3/8	.375	5/8	.625	7/8	.875
5/32	.15625	13/32	.40625	21/32	.65625	29/32	.90625
3/16	.1875	7/16	.4375	11/16	.6875	15/16	.9375
7/32	.21875	15/32	.46875	23/32	.71875	31/32	.96875
1/4	.25	1/2	.5	3/4	.75		

UNLESS OTHERWISE SPECIFIED
DIMENSIONS ARE IN INCHES
TOLERANCES ARE:

FRACTIONS	ANGLES
+/- 1/16"	+/- 1°
.XX"	.XXX"
+/- 0.03"	+/- 0.005"

DIMENSIONS TO SHARP POINTS

SHEET NAME		TITLE	
BRACKET INSTALL (2)		17251 BUMPER ON VOLVO VNR	
CURRENT CUSTOMER	STOCK NUMBER	VENDOR NUMBER	WEIGHT - LB.
WO#	DRAWN BY	DRAWN DATE	REV.
	LS	2/13/2018	B
SCALE	MODELLER	DRAWING NUMBER	NUMBER OF SHEETS
1:10	LS	AA-49225	2

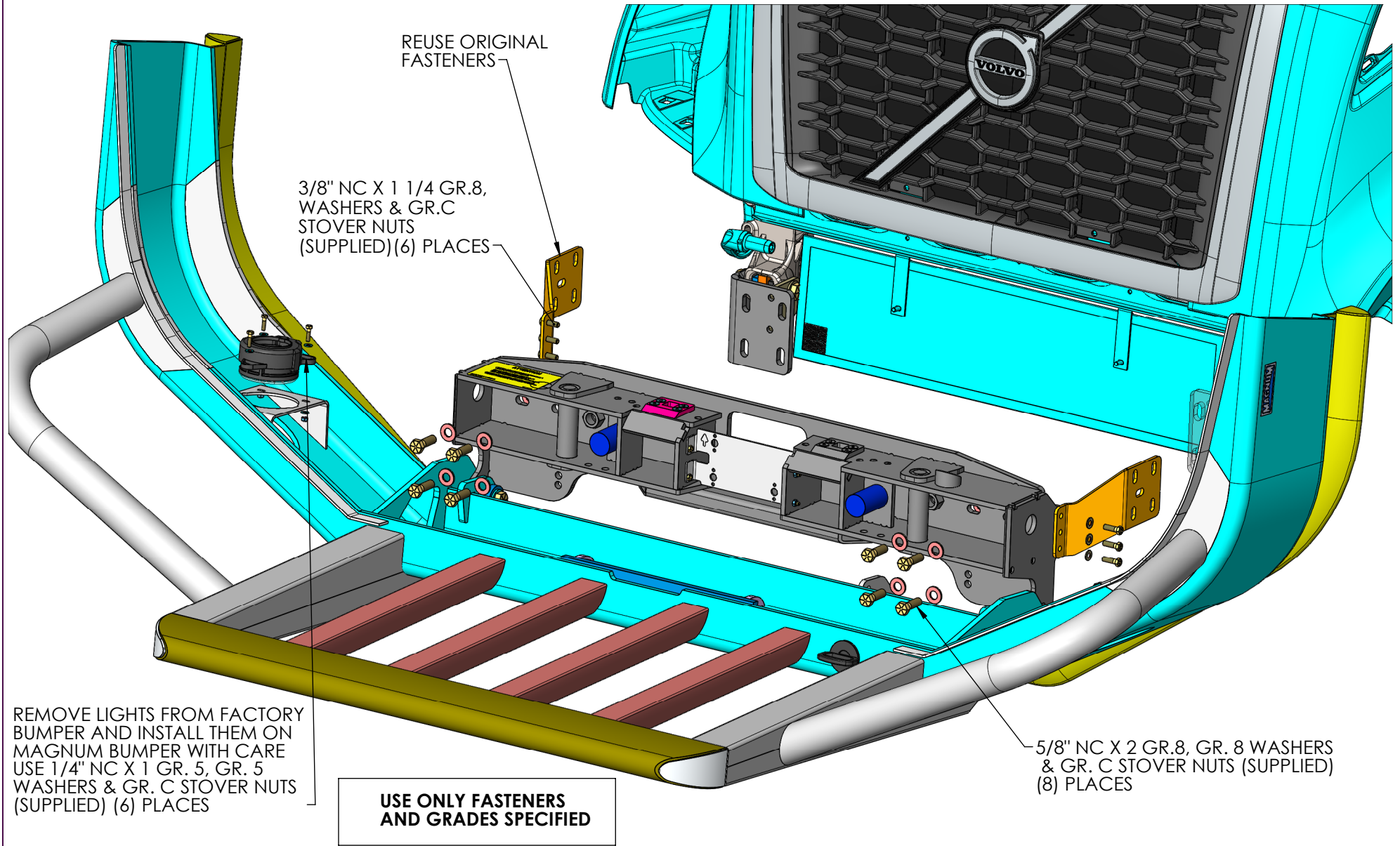

REMOVE LIGHTS FROM FACTORY BUMPER AND INSTALL THEM ON MAGNUM BUMPER WITH CARE USE 1/4" NC X 1 GR. 5, GR. 5 WASHERS & GR. C STOVER NUTS (SUPPLIED) (6) PLACES

USE ONLY FASTENERS AND GRADES SPECIFIED

5/8" NC X 2 GR.8, GR. 8 WASHERS & GR. C STOVER NUTS (SUPPLIED) (8) PLACES

MAGNUM TRAILER & EQUIPMENT INC.

FRACTIONS CHART					
1/32	.03125	9/32	.28125	17/32	.53125
1/16	.0625	5/16	.3125	9/16	.5625
3/32	.09375	11/32	.34375	13/16	.8125
1/8	.125	3/8	.375	19/32	.59375
5/32	.15625	13/32	.40625	5/8	.625
3/16	.1875	7/16	.4375	21/32	.65625
7/32	.21875	15/32	.46875	11/16	.6875
1/4	.25	1/2	.5	23/32	.71875
				31/32	.96875
				3/4	.75

UNLESS OTHERWISE SPECIFIED DIMENSIONS ARE IN INCHES TOLERANCES ARE:

FRACTIONS ANGLES
 +/- 1/16" +/- 1deg

DIMENSIONS TO SHARP POINTS

SHEET NAME		TITLE	
BUMPER INSTALL		17251 BUMPER ON VOLVO VNR	
CURRENT CUSTOMER	STOCK NUMBER	VENDOR NUMBER	WEIGHT - LB.
WO#	DRAWN BY	DRAWN DATE	REV.
SCALE	LS	2/13/2018	B
1:10	MODELLER	DRAWING NUMBER	NUMBER OF SHEETS
	LS	AA-49225	2

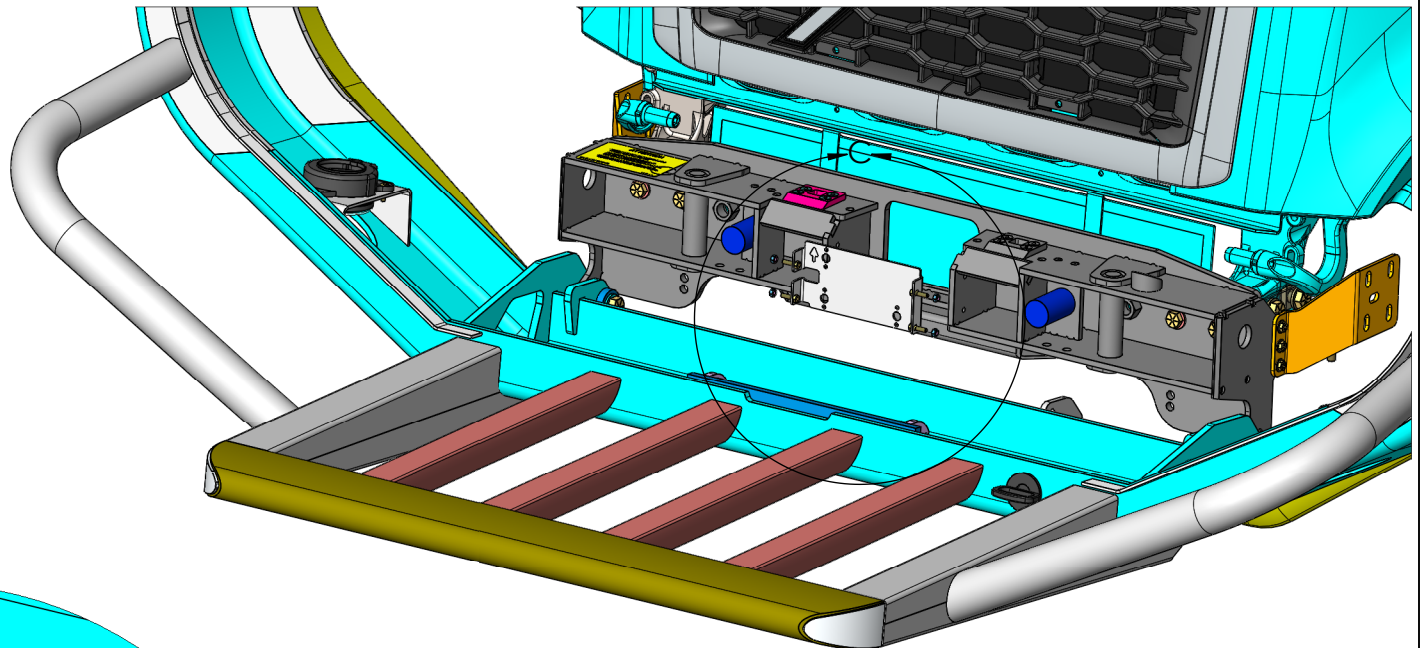

STEP (2):
 RECONNECT RADAR TO THE TRUCK
 (USE BRACKET SLOT TO FISH RADAR
 CABLE)

DETAIL C
 SCALE 1 : 5

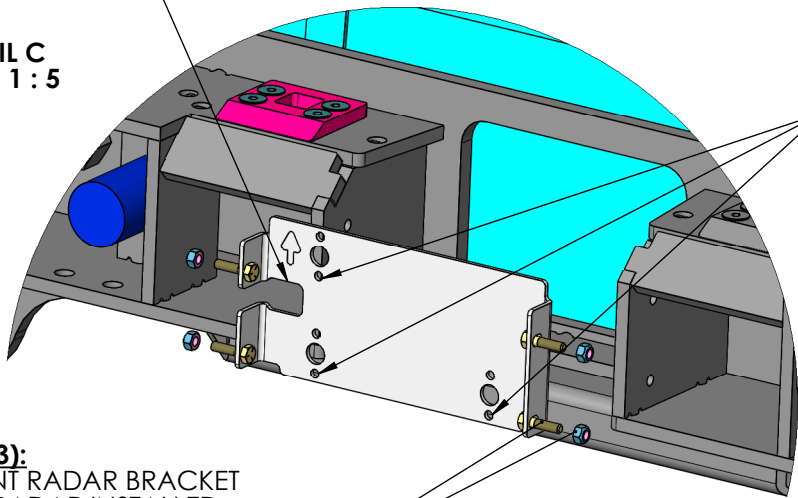

STEP (1):
 INSTALL RADAR INTO RADAR
 BRACKET SUPPLIED REUSING
 ORIGINAL ADJUSTABLE STAND-OFF
 AND FASTENERS

STEP (3):
 MOUNT RADAR BRACKET
 WITH RADAR INSTALLED
 ON IT USING 1/4" NC X 1"
 GR. 5 AND GR. C STOVER
 NUTS (SUPPLIED)(4) PLACES

NOTE:

IF EQUIPPED, RADAR MUST BE REMOVED BEFORE BUMPER INSTALLATION.

RADAR MUST BE RE-CALIBRATED AFTER BUMPER INSTALLATION. CALIBRATION CAN ONLY BE DONE BY AUTHORIZED PERSONNEL

**MAGNUM TRAILER
 &
 EQUIPMENT INC.**



FRACTIONS CHART

1/32	.03125	9/32	.28125	17/32	.53125	25/32	.78125
1/16	.0625	5/16	.3125	9/16	.5625	13/16	.8125
3/32	.09375	11/32	.34375	19/32	.59375	27/32	.84375
1/8	.125	3/8	.375	5/8	.625	7/8	.875
5/32	.15625	13/32	.40625	21/32	.65625	29/32	.90625
3/16	.1875	7/16	.4375	11/16	.6875	15/16	.9375
7/32	.21875	15/32	.46875	23/32	.71875	31/32	.96875
1/4	.25	1/2	.5	3/4	.75		

UNLESS OTHERWISE SPECIFIED
 DIMENSIONS ARE IN INCHES
 TOLERANCES ARE:

FRACTIONS	ANGLES
+/- 1/16"	+/- 1°
.XX"	.XXX"
+/- 0.03"	+/- 0.005"

DIMENSIONS TO SHARP POINTS

SHEET NAME		TITLE	
RADAR INSTALL		17251 BUMPER ON VOLVO VNR	
CURRENT CUSTOMER	STOCK NUMBER	VENDOR NUMBER	WEIGHT - LB.
WO#	DRAWN BY	DRAWN DATE	REV.
SCALE	LS	2/13/2018	B
1:10	MODELLER	DRAWING NUMBER	NUMBER OF SHEETS
	LS	AA-49225	2