

INSTALLATION NOTES:

1. REMOVE MOUNT BRACKETS FROM BUMPER ASSEMBLY
2. ATTACH MOUNT BASES TO TRUCK OUTSIDE OF FRAME WITH CLAMPS (TOP LIP OF MOUNT BRACKET SHOULD ALWAYS BE IN CONTACT WITH TRUCK RAIL FRAME)
3. MEASURE AT FACES SHOWN
4. THE CORRECT MEASUREMENT IS 43 1/2".
5. EXAMPLE: IF MEASUREMENT TAKEN IS 43 1/4" THEN SUBTRACT THIS FROM 43 1/2". THE DIFFERENCE IN THIS EXAMPLE IS 1/4". DIVIDE BY 2 EQUALS 1/8" PER SIDE. OUTER SHIMS ARE 1/16" THICK - TWO SHIMS PER SIDE ARE REQUIRED FOR THIS EXAMPLE
6. INSTALL OUTER SHIMS BETWEEN MOUNT BASE AND OUTSIDE OF TRUCK FRAME TO ACHIEVE 43 1/2" MEASUREMENT
7. TEST FIT INNER PLATE AND DETERMINE THE REQUIRED INNER SHIMS TO FILL THE GAP SO THE INNER PLATE SITS PARALLEL TO FRAME INNER SURFACE
8. ENSURE MOUNT BASE IS FIRMLY TOUCHING AND ALIGNED WITH END OF FRAME RAIL AND TIGHTEN NUTS TO TORQUES SHOWN

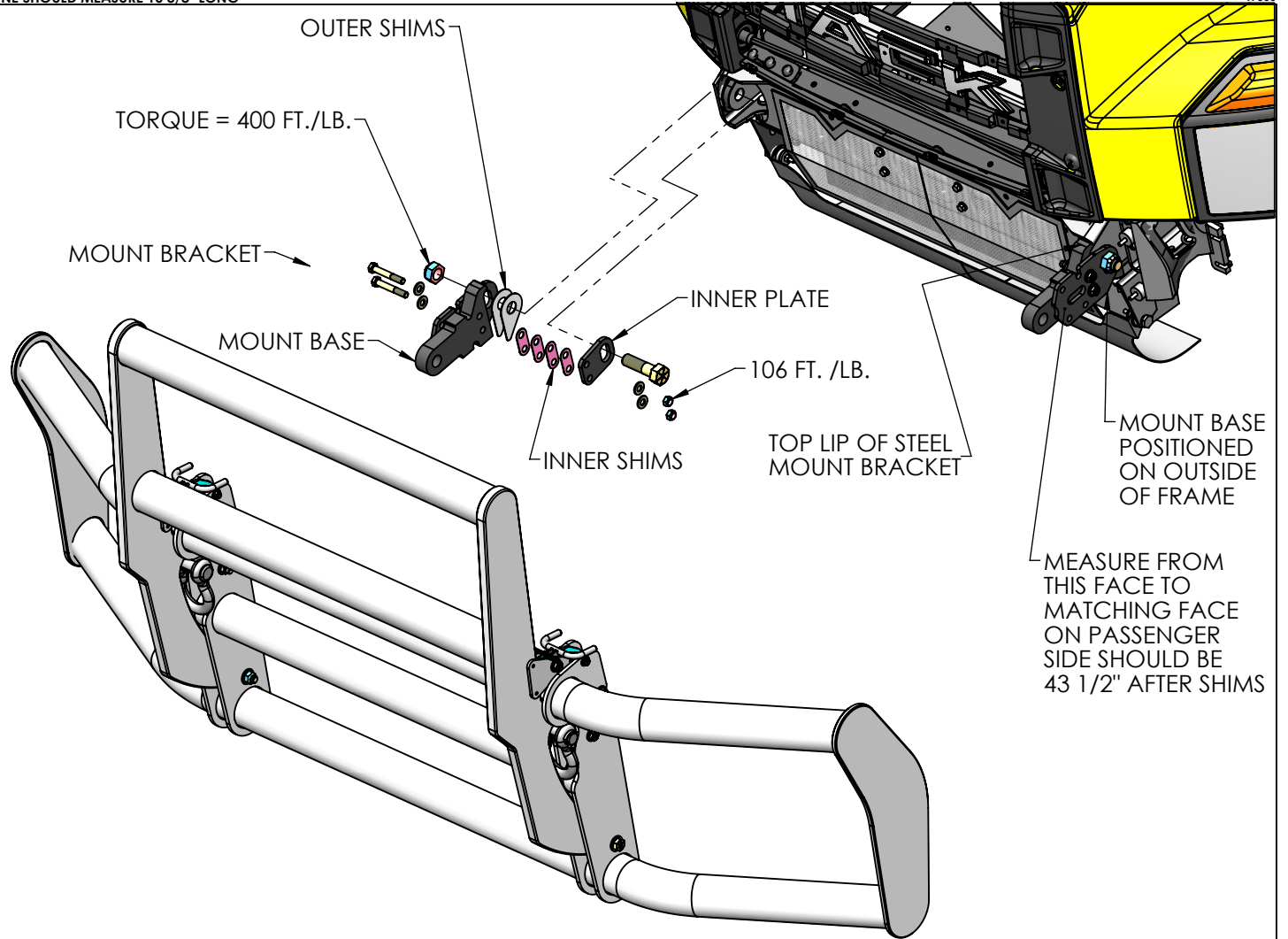

9. POSITION ALUMINUM BUMPER ASSEMBLY AND INSTALL (8) BOLTS AND FINAL TIGHTEN

**MAGNUM TRAILER & EQUIPMENT INC.**



FRACTIONS CHART

1/32	.03125	9/32	.28125	17/32	.53125	25/32	.78125
1/16	.0625	5/16	.3125	9/16	.5625	13/16	.8125
3/32	.09375	11/32	.34375	19/32	.59375	27/32	.84375
1/8	.125	3/8	.375	5/8	.625	7/8	.875
5/32	.15625	13/32	.40625	21/32	.65625	29/32	.90625
3/16	.1875	7/16	.4375	11/16	.6875	15/16	.9375
7/32	.21875	15/32	.46875	23/32	.71875	31/32	.96875
1/4	.25	1/2	.5	3/4	.75		

UNLESS OTHERWISE SPECIFIED DIMENSIONS ARE IN INCHES TOLERANCES ARE:

FRACTIONS	ANGLES
+/- 1/16"	+/- 1°
.XX"	.XXX"
+/- 0.03"	+/- 0.005"

DIMENSIONS TO SHARP POINTS

SHEET NAME	TITLE		
Sheet1	17244 BUMPER ON 2017 MACK CXU		
CURRENT CUSTOMER	STOCK NUMBER	VENDOR NUMBER	WEIGHT - LB.
			189.
WO#	DRAWN BY	DRAWN DATE	REV.
	GW	3/01/2018	A
SCALE	MODELLER	DRAWING NUMBER	NUMBER OF SHEETS
1:14	HM	AA-47360	1