

**INSTALLATION STEPS:**

1. REMOVE BUMPER BOLTS AND SLIDE FORWARD TO REMOVE FACTORY TOWING SHACKLES (4) ONE SIDE AT A TIME. PUT ASIDE FOR LATER REINSTALLATION
2. DO NOT REMOVE FACTORY BUMPER - IT IS NOT SHOWN TO CLARIFY THE DRAWINGS
3. IF NECESSARY, REMOVE MOUNT BOLTS (3) AND PLACE ALUMINUM ASSEMBLY (6) ASIDE, BOLT (7) NEED NOT BE COMPLETELY REMOVED
4. POSITION MOUNT BRACKETS THROUGH FACTORY BUMPER OPENINGS AND ALIGN LARGE SLOT WITH FRAME HOLE. (TOP LIP OF BRACKET SHOULD ALWAYS BE IN CONTACT WITH TRUCK RAIL FRAME)
5. INSTALL CONNECTING PLATE (5) ON INSIDE OF FRAME RAILS AND INSTALL BOLTS (2) WITH NUTS AND WASHERS. ALSO, INSTALL WITH SHIMS SUPPLIED AS SHOWN ON PAGE 2. DO NOT FULLY TIGHTEN NUTS AT THIS TIME - SNUG ONLY BEFORE ALIGNMENT CHECK
6. REINSTALL ALUMINUM ASSEMBLY (6) AND REPLACE MOUNT BOLTS (3) - LOOSEN BOLTS (1) (2) IF REQUIRED TO PROVIDE EXTRA CLEARANCE
7. CHECK ALIGNMENT
8. TIGHTEN BOLTS: BOLT (1) TORQUE = 400 FT./LB. BOLT (2) TORQUE = 200 FT./LB.
9. INSTALL TOW SHACKLES (4)

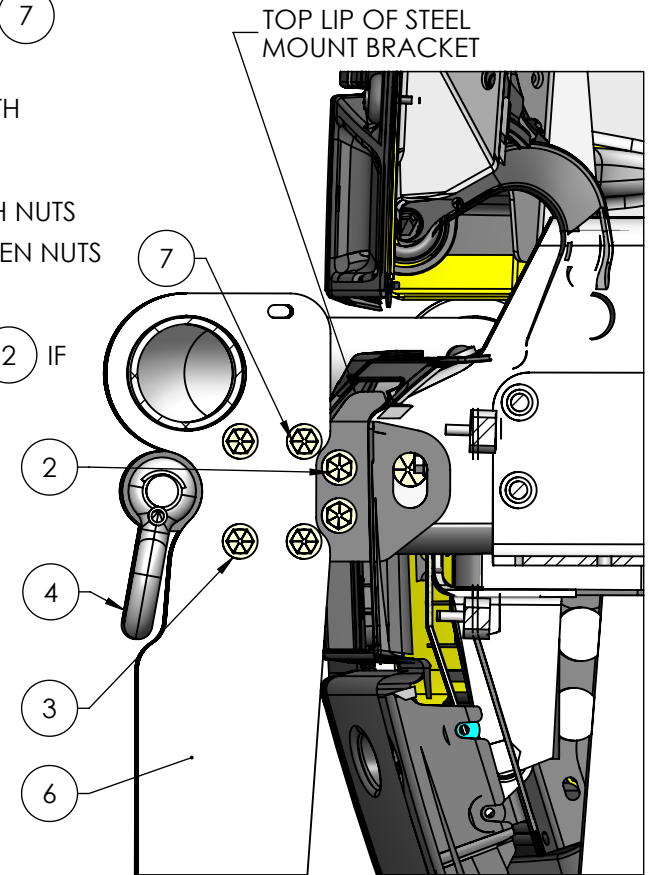
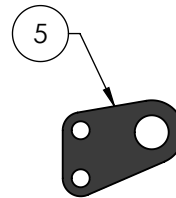
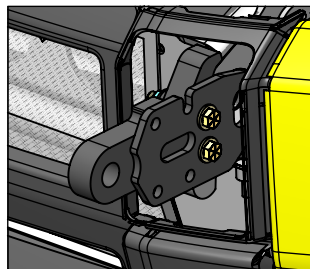

A	SHIMS ADDED - SEE PAGE 2	1/26/2018	LS
REV.	CHANGES OR ADDITIONS	DATE	REV BY

**MAGNUM TRAILER & EQUIPMENT INC.**



**FRACTIONS CHART**

1/32	.03125	9/32	.28125	17/32	.53125	25/32	.78125
1/16	.0625	5/16	.3125	9/16	.5625	13/16	.8125
3/32	.09375	11/32	.34375	19/32	.59375	27/32	.84375
1/8	.125	3/8	.375	5/8	.625	7/8	.875
5/32	.15625	13/32	.40625	21/32	.65625	29/32	.90625
3/16	.1875	7/16	.4375	11/16	.6875	15/16	.9375
7/32	.21875	15/32	.46875	23/32	.71875	31/32	.96875
1/4	.25	1/2	.5	3/4	.75		

UNLESS OTHERWISE SPECIFIED DIMENSIONS ARE IN INCHES TOLERANCES ARE:

FRACTIONS ANGLES  
+/- 1/16" +/- 1deg

DIMENSIONS TO SHARP POINTS

SHEET NAME <b>NOTES</b>	TITLE <b>17243 BUMPER ON MACK TRUCK</b>		
CURRENT CUSTOMER	STOCK NUMBER	VENDOR NUMBER	WEIGHT - LB. 0.0
<b>WO#</b>	DRAWN BY HM	DRAWN DATE 8/31/2017	REV. <b>B</b>
SCALE 1:6	MODELLER HM	DRAWING NUMBER <b>AA-47294</b>	NUMBER OF SHEETS 2

**NOTE:**

△ A USE SHIMS 8 AND 9 SUPPLIED AS NEED IT FOR A PERFECT FIT.

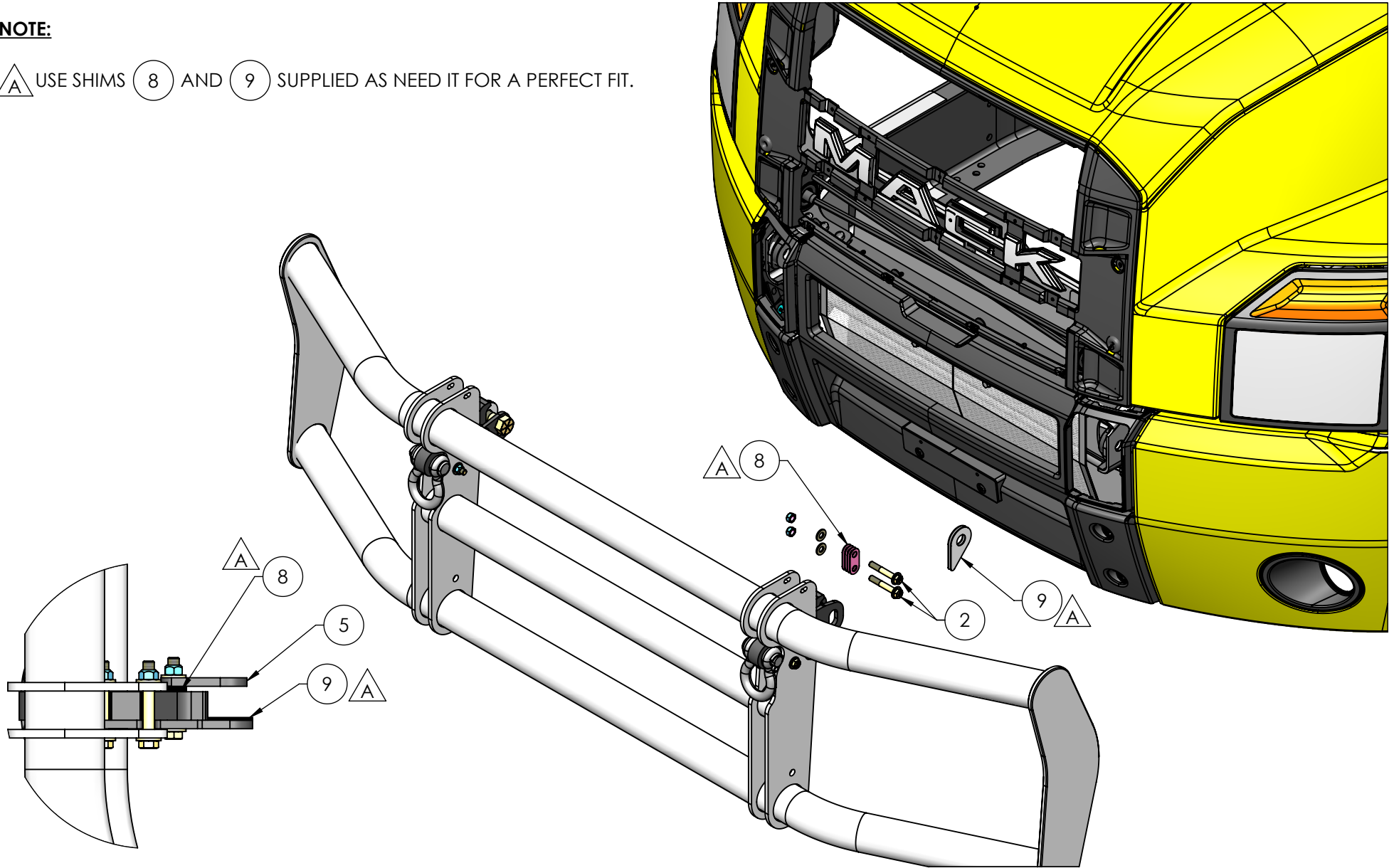

**MAGNUM TRAILER  
&  
EQUIPMENT INC.**



**FRACTIONS CHART**

1/32	.03125	9/32	.28125	17/32	.53125	25/32	.78125
1/16	.0625	5/16	.3125	9/16	.5625	13/16	.8125
3/32	.09375	11/32	.34375	19/32	.59375	27/32	.84375
1/8	.125	3/8	.375	5/8	.625	7/8	.875
5/32	.15625	13/32	.40625	21/32	.65625	29/32	.90625
3/16	.1875	7/16	.4375	11/16	.6875	15/16	.9375
7/32	.21875	15/32	.46875	23/32	.71875	31/32	.96875
1/4	.25	1/2	.5	3/4	.75		

UNLESS OTHERWISE SPECIFIED  
DIMENSIONS ARE IN INCHES  
TOLERANCES ARE:

FRACTIONS	ANGLES
+/- 1/16"	+/- 1°
.XX"	.XXX"
+/- 0.03"	+/- 0.005"

DIMENSIONS TO SHARP POINTS

SHEET NAME		TITLE	
Sheet1		17243 BUMPER ON MACK TRUCK	
CURRENT CUSTOMER	STOCK NUMBER	VENDOR NUMBER	WEIGHT - LB.
			0.0
WO#	DRAWN BY	DRAWN DATE	REV.
	HM	8/31/2017	B
SCALE	MODELLER	DRAWING NUMBER	NUMBER OF SHEETS
1:12	HM	AA-47294	2