

INSTALL STEPS

- 1) REMOVE NUTS, WASHERS AND SUPPORT SPACERS FROM STUDS - 2 PLACES.
 - 2) OPEN THE HOOD AND REMOVE THE SRPINGS AND SHOULDER WASHERS IN THE BACK OF THE TOW SOCKETS. CLOSE THE HOOD.
 - 3) WITH BUMPER IN THE CLOSED POSITION SLIDE THE BRACKETS INTO THE TOW SOCKETS.
 - 4) CAREFULLY OPEN BUMPER, ENSURING IT DOES NOT SLIP OUT OF THE TOW SOCKETS.
 - 5) OPEN TRUCK HOOD AND INSTALL NUTS, WASHERS AND SUPPORT SPACERS AS SHOWN IN **DETAIL A AND CROP VIEW.**
 - 6) FULLY TIGHTEN NUTS ONTO STUD. TORQUE = 210 FT-LB. DO NOT EXCEED THIS VALUE OR STRIPPING WILL OCCUR. ENSURE THAT STUD IS FREE OF LUBRICATION BEFORE TIGHTENING TO THIS VALUE.
- IF LOCTITE IS USED DECREASE TORQUE VALUE ACCORDING TO THE MANUFACTURERS RECOMMENDATION.
- 7) CLOSE HOOD AND BUMPER.
 - 8) CHECK THE BUMPER FOR FREE MOVEMENT AND IF IDENTIFIED ADD ONE OR MORE WHITE SHIMS AS PER MAGNUM INSTRUCTIONS. CONGRATULATIONS, THE INSTALL IS NOW COMPLETE.

NOTE: TOW SHACKLE & CLEVIS NOT VISIBLE IN THIS VIEW, VISIBLE ON SECOND SHEET WHEN THE BUMPER IS CLOSED

NUTS, SPRING WASHERS AND SUPPORT SPACER ARE INSTALLED AFTER BUMPER IS "PLUGGED" INTO TOW SOCKETS SEE DETAIL "A" AND CROP VIEW

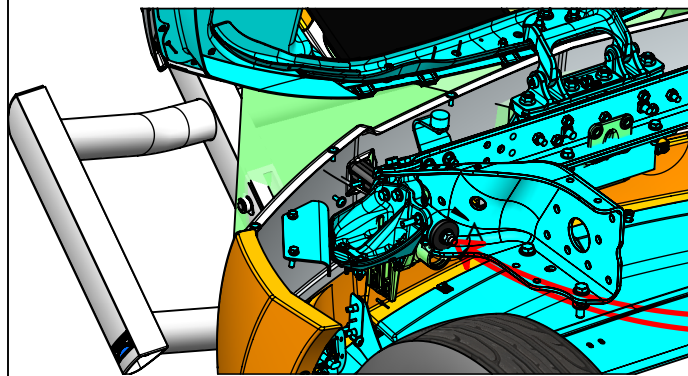
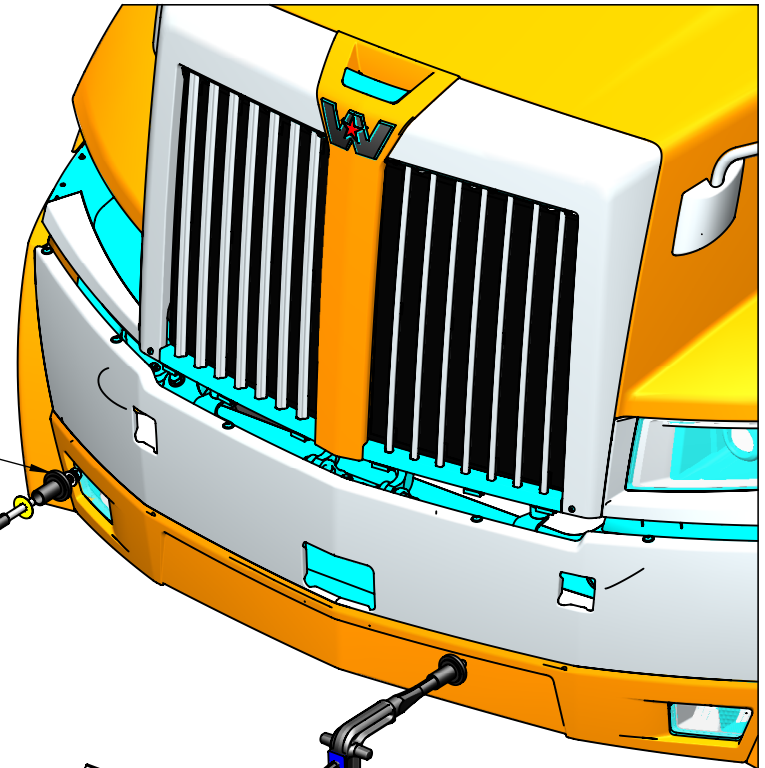

DETAIL A



CROP VIEW

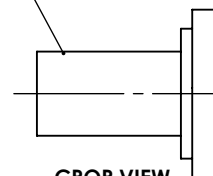

SPRING WASHERS

STOVER NUT

CONCAVE SIDE

SPRING WASHERS MUST BE PLACED IN AN INVERTED STACK CONFIGURATION TYP (2)

MAGNUM TRAILER & EQUIPMENT INC.



FRACTIONS CHART

1/32	.03125	9/32	.28125	17/32	.53125	25/32	.78125
1/16	.0625	5/16	.3125	9/16	.5625	13/16	.8125
3/32	.09375	11/32	.34375	19/32	.59375	27/32	.84375
1/8	.125	3/8	.375	5/8	.625	7/8	.875
5/32	.15625	13/32	.40625	21/32	.65625	29/32	.90625
3/16	.1875	7/16	.4375	11/16	.6875	15/16	.9375
7/32	.21875	15/32	.46875	23/32	.71875	31/32	.96875
1/4	.25	1/2	.5	3/4	.75		

UNLESS OTHERWISE SPECIFIED DIMENSIONS ARE IN INCHES TOLERANCES ARE:

FRACTIONS ANGLES
+/- 1/16" +/- 1deg

DIMENSIONS TO SHARP POINTS

SHEET NAME

Sheet1

CURRENT CUSTOMER

WO#

SCALE

1:4

TITLE

17225 BUMPER ON 2015 WESTERN STAR 5700 1400in RAD

STOCK NUMBER

DRAWN BY

LS

MODELLER

HM

VENDOR NUMBER

DRAWING NUMBER

AA-44539

DRAWN DATE

11/2/2017

REV.

E

WEIGHT - LB.

NUMBER OF SHEETS

2

DETAIL B
SCALE 1 : 5

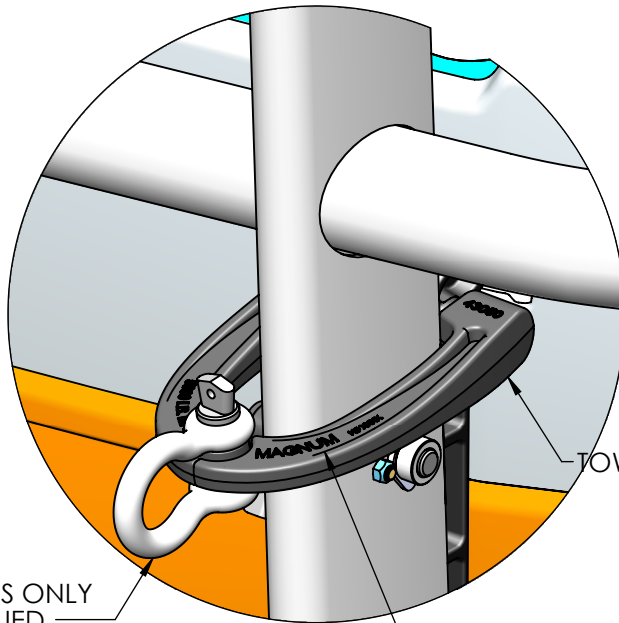

TOW-CLEVIS SUPPLIED

SECURE TOW-CLEVIS ONLY WITH SHACLE SUPPLIED

INSTALL & USE TOW COMPONENTS ONLY WHEN TOWING.
INSPECT TOWING COMPONENTS BEFORE INSTALLATION.

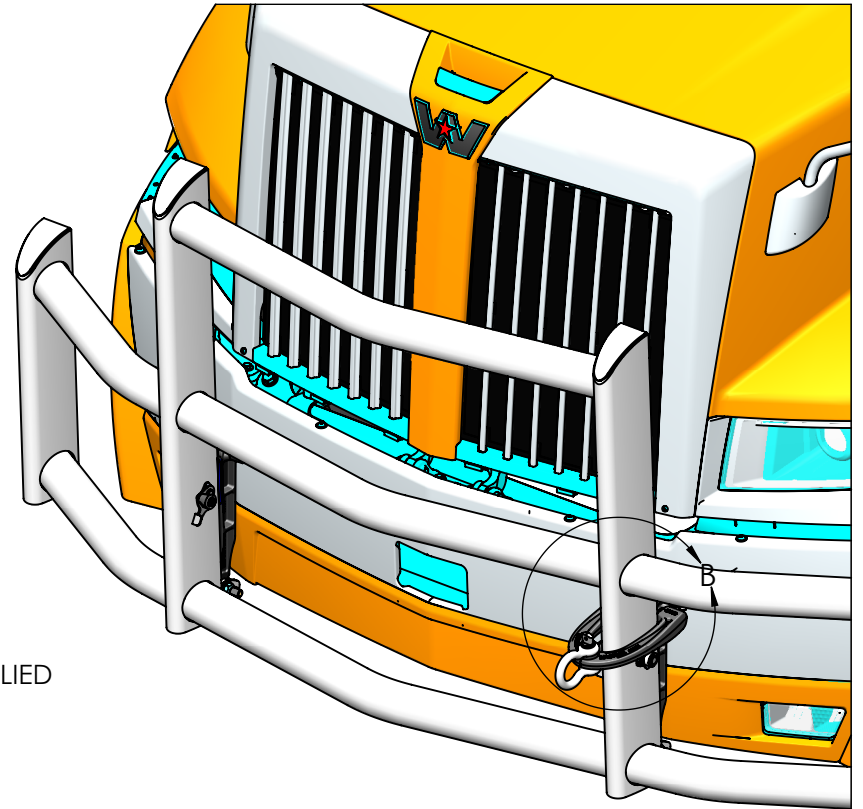

MAGNUM TRAILER & EQUIPMENT INC.



FRACTIONS CHART

1/32	.03125	9/32	.28125	17/32	.53125	25/32	.78125
1/16	.0625	5/16	.3125	9/16	.5625	13/16	.8125
3/32	.09375	11/32	.34375	19/32	.59375	27/32	.84375
1/8	.125	3/8	.375	5/8	.625	7/8	.875
5/32	.15625	13/32	.40625	21/32	.65625	29/32	.90625
3/16	.1875	7/16	.4375	11/16	.6875	15/16	.9375
7/32	.21875	15/32	.46875	23/32	.71875	31/32	.96875
1/4	.25	1/2	.5	3/4	.75		

UNLESS OTHERWISE SPECIFIED DIMENSIONS ARE IN INCHES TOLERANCES ARE:

FRACTIONS	ANGLES
+/- 1/16"	+/- 1°
.XX"	.XXX"
+/- 0.03"	+/- 0.005"

DIMENSIONS TO SHARP POINTS

SHEET NAME		TITLE		
Sheet2		17225 BUMPER ON 2015 WESTERN STAR 5700 1400in RAD		
CURRENT CUSTOMER	STOCK NUMBER	VENDOR NUMBER	WEIGHT - LB.	
			0.0	
WO#	DRAWN BY	DRAWN DATE	REV.	
	LS	11/2/2017	E	
SCALE	MODELLER	DRAWING NUMBER	NUMBER OF SHEETS	
1:4	HM	AA-44539	2	