

MAGNUM TRAILER & EQUIPMENT INC.



FRACTIONS CHART							
1/32	.03125	9/32	.28125	17/32	.53125	25/32	.78125
1/16	.0625	5/16	.3125	9/16	.5625	13/16	.8125
3/32	.09375	11/32	.34375	19/32	.59375	27/32	.84375
1/8	.125	3/8	.375	5/8	.625	7/8	.875
5/32	.15625	13/32	.40625	21/32	.65625	29/32	.90625
3/16	.1875	7/16	.4375	11/16	.6875	15/16	.9375
7/32	.21875	15/32	.46875	23/32	.71875	31/32	.96875
1/4	.25	1/2	.5	3/4	.75		

UNLESS OTHERWISE SPECIFIED DIMENSIONS ARE IN INCHES
TOLERANCES ARE:

FRACTIONS	ANGLES
+/- 1/16"	+/- 1°
.XX"	.XXX"
+/- 0.03"	+/- 0.005"

DIMENSIONS TO SHARP POINTS

SHEET NAME STEP 1
CURRENT CUSTOMER
WO#
SCALE 1:10

TITLE 17211 ON FREIGHTLINER CASCADIA			
STOCK NUMBER	VENDOR NUMBER	WEIGHT - LB. 467.	
DRAWN BY BNS	DRAWN DATE 12/29/2015	REV.	
MODELLER	DRAWING NUMBER AA-42263	NUMBER OF SHEETS 2	

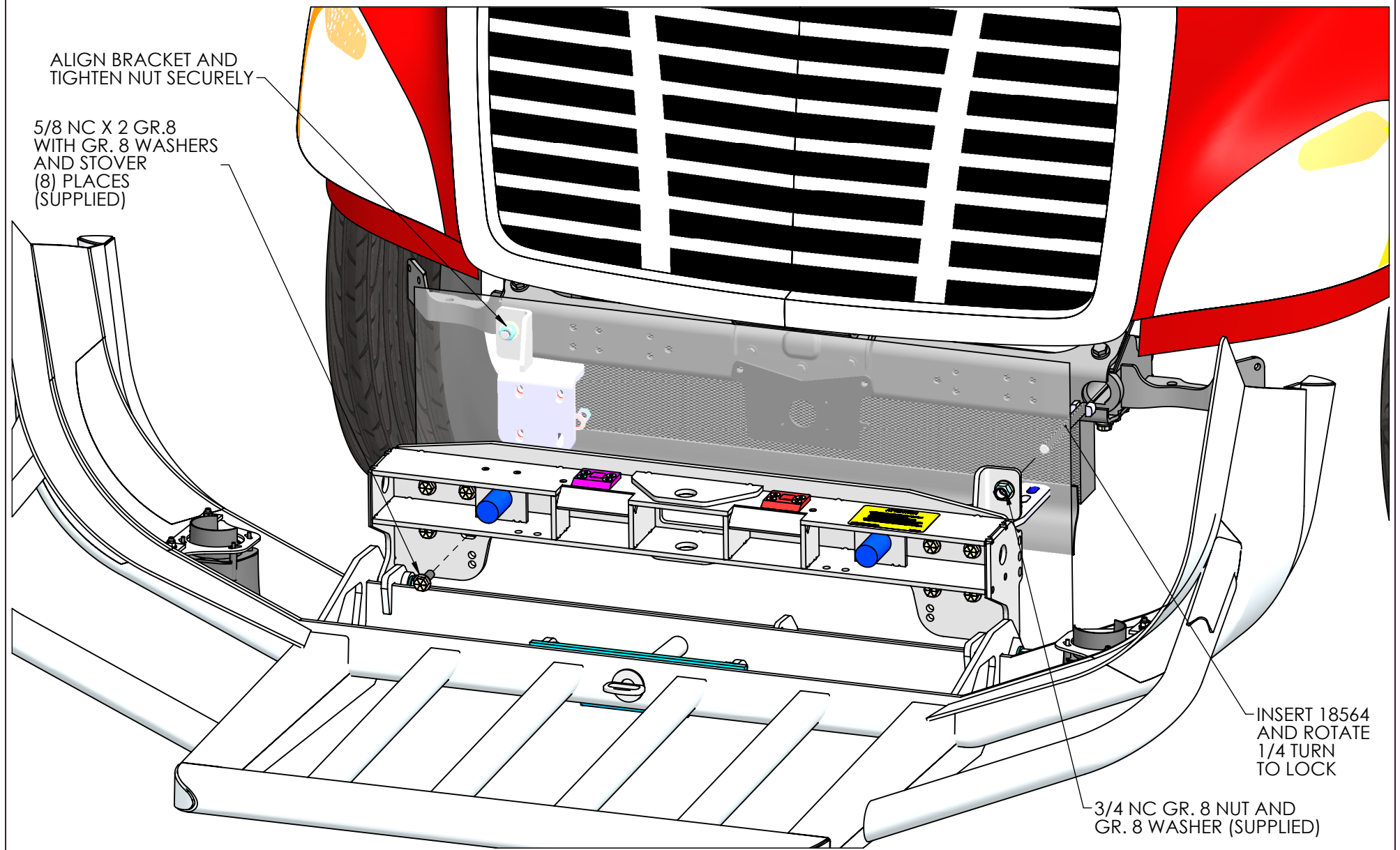

MAGNUM TRAILER & EQUIPMENT INC.



PROCESS CODES

- | | |
|---------------------------|----------------------|
| A - MODIFY SURFACE FINISH | Q - PAINT OR COATING |
| B - BURN (FLAME) | R - ROLLED |
| C - CUT TO LENGTH | S - SHEAR |
| D - DRILL | T - TRIM |
| F - FORM | V - LAYOUT |
| H - HI DEF PLASMA | W - WATER CUT |
| K - CAST | X - EXTRUDE |
| L - LASER | Y - MODIFY |
| M - MACHINE | Z - HEAT TREAT |
| P - PUNCH | |

UNLESS OTHERWISE SPECIFIED
DIMENSIONS ARE IN INCHES
TOLERANCES ARE:

FRACTIONS ANGLES
+/- 1/16" +/- 1deg

DIMENSIONS TO SHARP POINTS

SHEET NAME
STEP 2

CURRENT CUSTOMER

WO#

SCALE

1:10

TITLE

17211 ON FREIGHTLINER CASCADIA

STOCK NUMBER

VENDOR NUMBER

WEIGHT - LB.

DRAWN BY
BNS

DRAWN DATE
12/29/2015

REV.

MODELLER

DRAWING NUMBER

AA-42263

NUMBER OF SHEETS

2