

MAGNUM TRAILER & EQUIPMENT INC.



FRACTIONS CHART

1/32	.03125	9/32	.28125	17/32	.53125	25/32	.78125
1/16	.0625	5/16	.3125	9/16	.5625	13/16	.8125
3/32	.09375	11/32	.34375	19/32	.59375	27/32	.84375
1/8	.125	3/8	.375	5/8	.625	7/8	.875
5/32	.15625	13/32	.40625	21/32	.65625	29/32	.90625
3/16	.1875	7/16	.4375	11/16	.6875	15/16	.9375
7/32	.21875	15/32	.46875	23/32	.71875	31/32	.96875
1/4	.25	1/2	.5	3/4	.75		

UNLESS OTHERWISE SPECIFIED DIMENSIONS ARE IN INCHES TOLERANCES ARE:

FRACTIONS ANGLES
+/- 1/16" +/- 1deg

DIMENSIONS TO SHARP POINTS

SHEET NAME
STEP 1

CURRENT CUSTOMER

WO#

SCALE

1:10

TITLE

17199 BUMPER ON 2015 WESTERN STAR 5700 1400in RAD

STOCK NUMBER

VENDOR NUMBER

WEIGHT - LB.

0.0

DRAWN BY
BNS

DRAWN DATE

2015-10-01

REV.

A

MODELLER
BNS

DRAWING NUMBER

AA-40575

NUMBER OF SHEETS

2

ATTACH LIGHTS TO BRACKETS
AND MOUNT TO BUMPER USING:
3/8 NC X 1 1/4 GR.5
WITH GR.2 WASHERS
AND GR.C STOVER NUTS
(4) PLACES
(SUPPLIED)

ALIGN BRACKET
AND TIGHTEN NUT
SECURELY

5/8 NC X 2 GR.8
WITH GR. 8 WASHERS
AND STOVER
(8) PLACES
(SUPPLIED)

INSERT 18564
AND ROTATE
1/4 TURN
TO LOCK

3/4 NC GR. 8 NUT AND
GR. 8 WASHER (SUPPLIED)

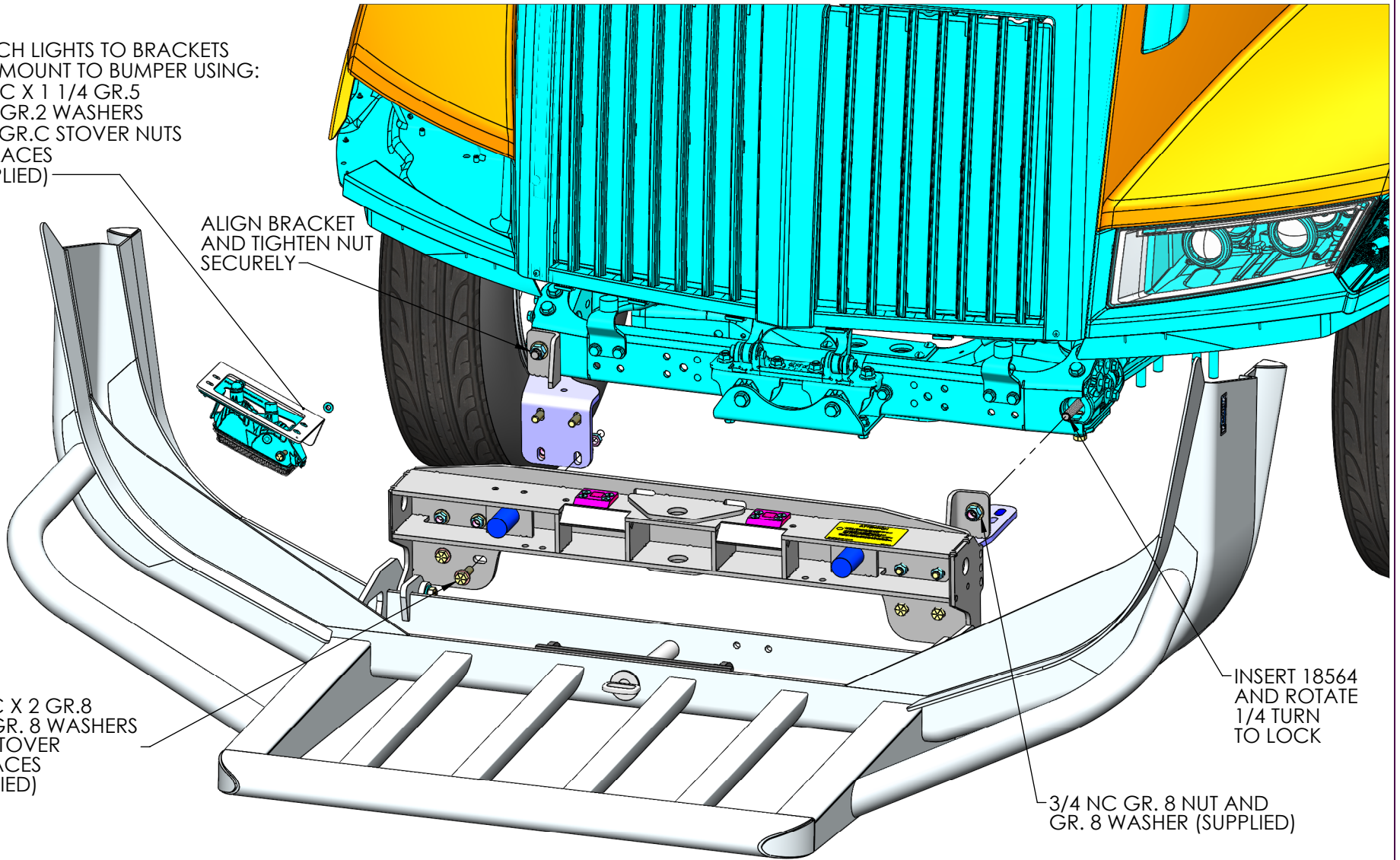

**MAGNUM TRAILER
&
EQUIPMENT INC.**



FRACTIONS CHART

1/32	.03125	9/32	.28125	17/32	.53125	25/32	.78125
1/16	.0625	5/16	.3125	9/16	.5625	13/16	.8125
3/32	.09375	11/32	.34375	19/32	.59375	27/32	.84375
1/8	.125	3/8	.375	5/8	.625	7/8	.875
5/32	.15625	13/32	.40625	21/32	.65625	29/32	.90625
3/16	.1875	7/16	.4375	11/16	.6875	15/16	.9375
7/32	.21875	15/32	.46875	23/32	.71875	31/32	.96875
1/4	.25	1/2	.5	3/4	.75		

UNLESS OTHERWISE SPECIFIED
DIMENSIONS ARE IN INCHES
TOLERANCES ARE:

FRACTIONS ANGLES
+/- 1/16" +/- 1deg

DIMENSIONS TO SHARP POINTS

SHEET NAME
STEP 2

CURRENT CUSTOMER

WO#

SCALE

1:12

TITLE

17199 BUMPER ON 2015 WESTERN STAR 5700 1400in RAD

STOCK NUMBER

VENDOR NUMBER

WEIGHT - LB.
0.0

DRAWN BY
BNS

DRAWN DATE
2015-10-01

REV.
A

MODELLER
BNS

DRAWING NUMBER
AA-40575

NUMBER OF SHEETS
2