

**NOTE:**

**2012+ MODEL YEAR:**

1/2" X 2 GR8  
GR 8 WASHER  
1/2" GR8 NYLOCK NUT  
TYP. (2)  
(OR M12 10.9)

**2011 & PREVIOUS MODEL YEAR**

5/16" X 2 GR8  
GR 8 WASHER  
5/16" GR8 NYLOCK NUT  
TYP. (2)  
(OR M8 10.9)

(NOT SUPPLIED)

INSTALL TOW HOOK  
MOUNTS THEN INSTALL  
BUMPER USING (6) BOLTS

SEE NOTE

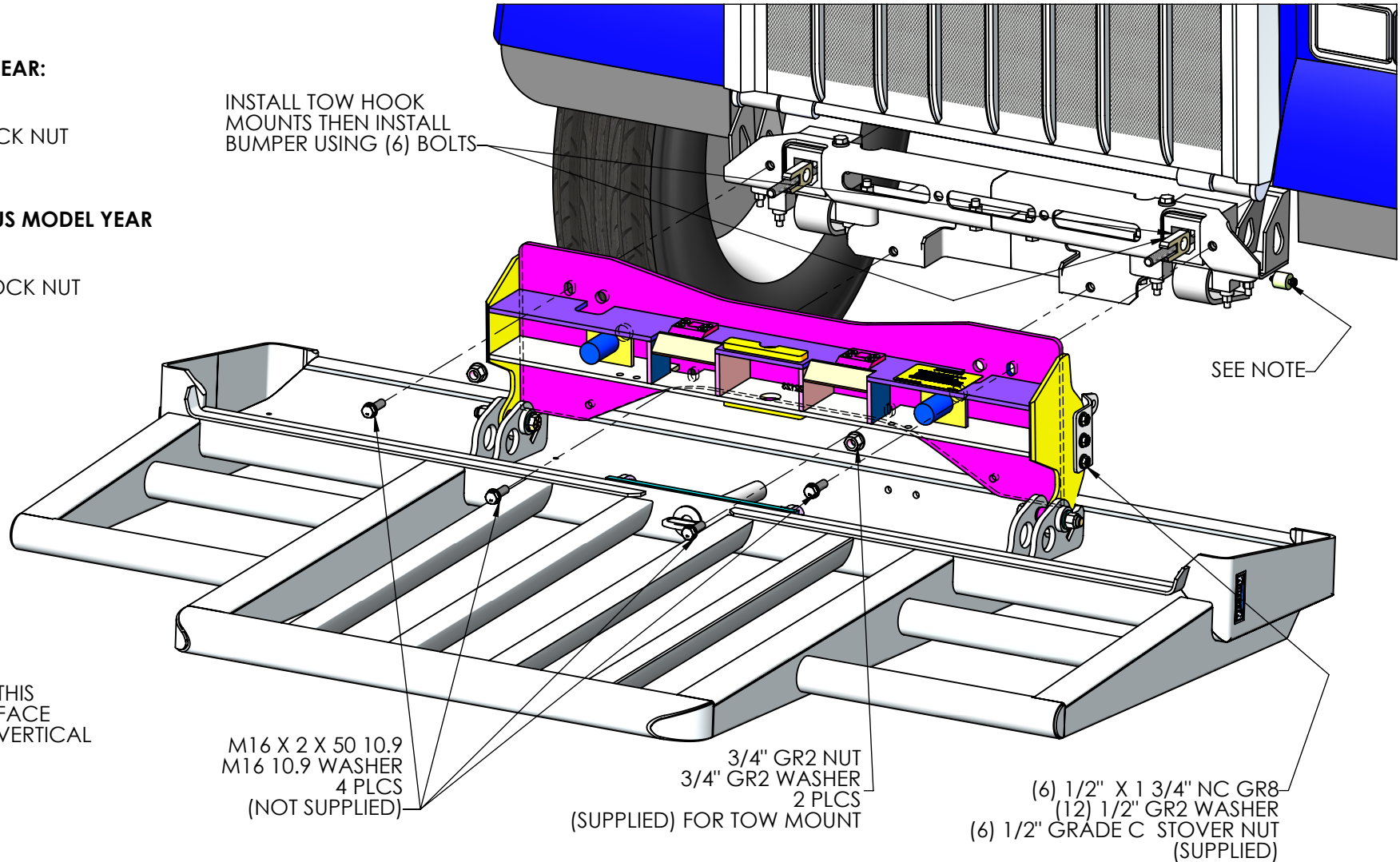

**USE FASTENER GRADES SPECIFIED**

**MAGNUM TRAILER  
&  
EQUIPMENT INC.**



**FRACTIONS CHART**

1/32	.03125	9/32	.28125	17/32	.53125	25/32	.78125
1/16	.0625	5/16	.3125	9/16	.5625	13/16	.8125
3/32	.09375	11/32	.34375	19/32	.59375	27/32	.84375
1/8	.125	3/8	.375	5/8	.625	7/8	.875
5/32	.15625	13/32	.40625	21/32	.65625	29/32	.90625
3/16	.1875	7/16	.4375	11/16	.6875	15/16	.9375
7/32	.21875	15/32	.46875	23/32	.71875	31/32	.96875
1/4	.25	1/2	.5	3/4	.75		

UNLESS OTHERWISE SPECIFIED  
DIMENSIONS ARE IN INCHES  
TOLERANCES ARE:

FRACTIONS	ANGLES
+/- 1/16"	+/- 1°
.XX"	.XXX"
+/- 0.03"	+/- 0.005"

**DIMENSIONS TO SHARP POINTS**

SHEET NAME

**INSTALL**

CURRENT CUSTOMER

**WO#**

SCALE

1:12

TITLE

**17102 BUMPER ON 2010 KENWORTH W900B**

STOCK NUMBER

VENDOR NUMBER

WEIGHT - LB.

781.

DRAWN BY

BS

DRAWN DATE

10/3/2011

REV.

**B**

MODELLER

BS

DRAWING NUMBER

**AA-22134**

NUMBER OF SHEETS

1

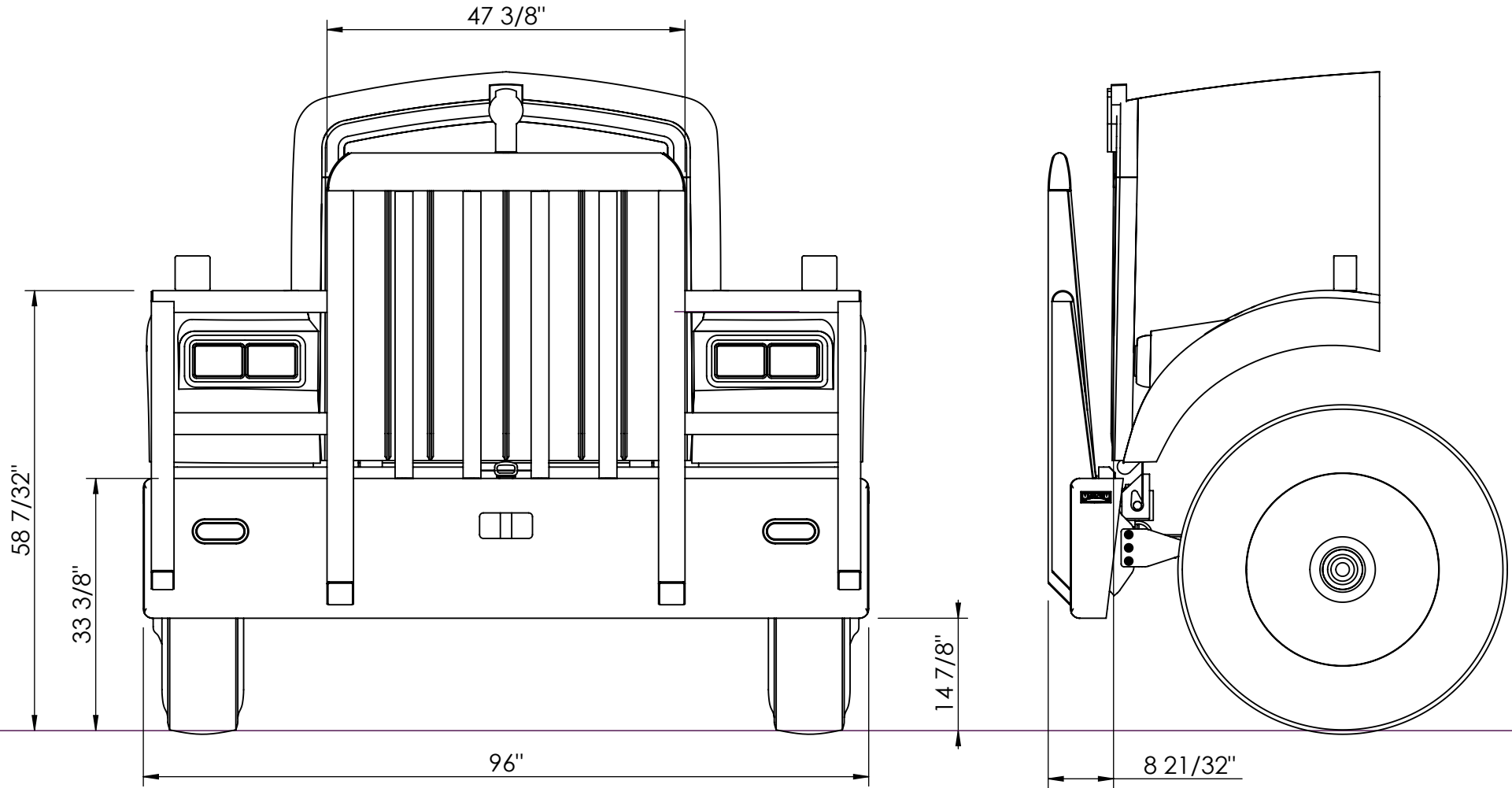

**MAGNUM TRAILER  
&  
EQUIPMENT INC.**



**FRACTIONS CHART**

1/32	.03125	9/32	.28125	17/32	.53125	25/32	.78125
1/16	.0625	5/16	.3125	9/16	.5625	13/16	.8125
3/32	.09375	11/32	.34375	19/32	.59375	27/32	.84375
1/8	.125	3/8	.375	5/8	.625	7/8	.875
5/32	.15625	13/32	.40625	21/32	.65625	29/32	.90625
3/16	.1875	7/16	.4375	11/16	.6875	15/16	.9375
7/32	.21875	15/32	.46875	23/32	.71875	31/32	.96875
1/4	.25	1/2	.5	3/4	.75		

UNLESS OTHERWISE SPECIFIED  
DIMENSIONS ARE IN INCHES  
TOLERANCES ARE:

FRACTIONS	ANGLES
+/- 1/16"	+/- 1°
.XX"	.XXX"
+/- 0.03"	+/- 0.005"

**DIMENSIONS TO SHARP POINTS**

SHEET NAME  
**SALES DIMENSIONS**

CURRENT CUSTOMER

**WO#**

SCALE 1:20

TITLE  
**17102 BUMPER ON 2010 KENWORTH W900B**

STOCK NUMBER

VENDOR NUMBER

WEIGHT - LB.

781.

DRAWN BY

BS

DRAWN DATE

10/3/2011

REV.

**B**

MODELLER

BS

DRAWING NUMBER

**AA-22134**

NUMBER OF SHEETS

1