

ONLY USE FASTENERS AND GRADES SPECIFIED

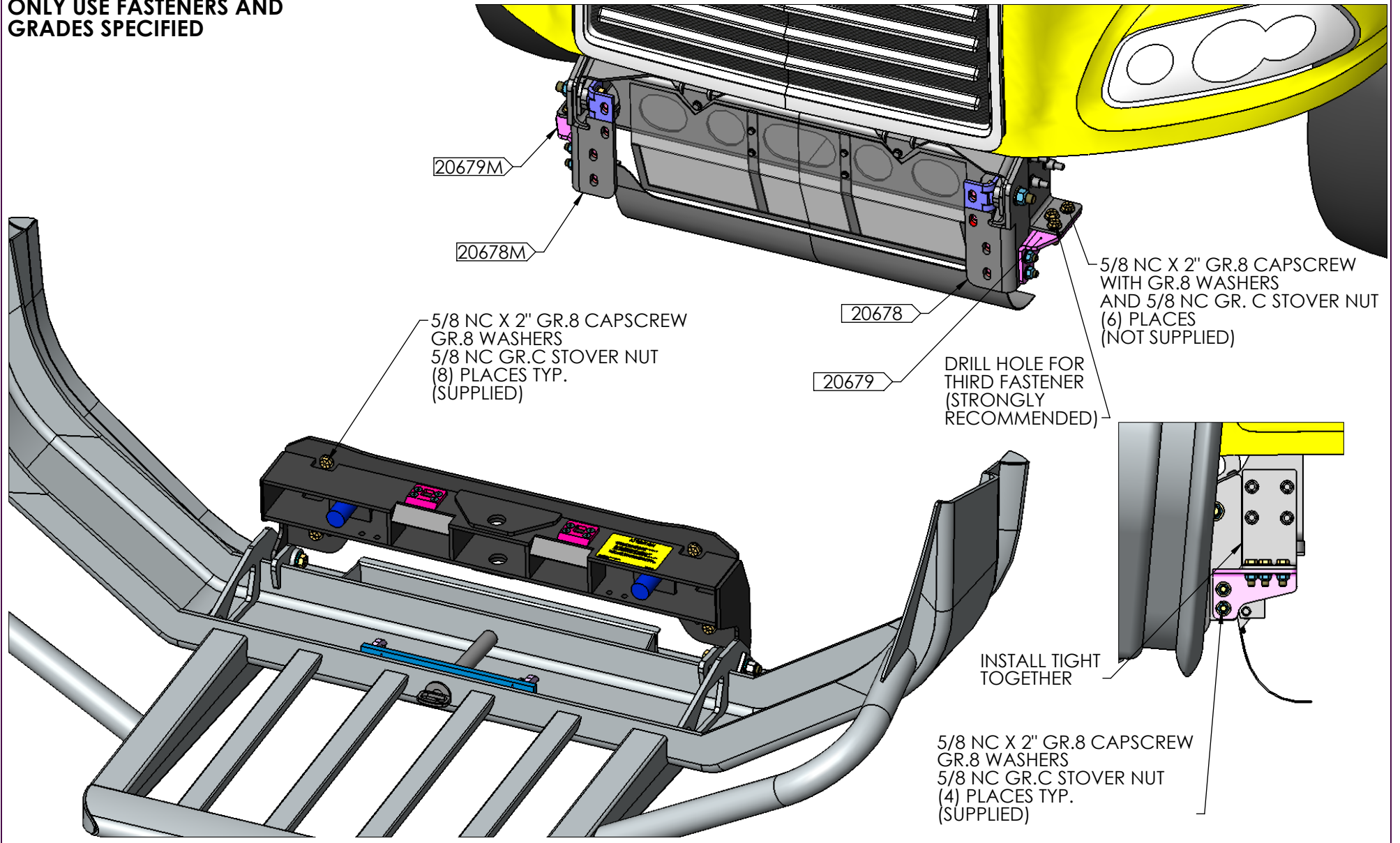

MAGNUM TRAILER & EQUIPMENT INC.



FRACTIONS CHART

1/32	.03125	9/32	.28125	17/32	.53125	25/32	.78125
1/16	.0625	5/16	.3125	9/16	.5625	13/16	.8125
3/32	.09375	11/32	.34375	19/32	.59375	27/32	.84375
1/8	.125	3/8	.375	5/8	.625	7/8	.875
5/32	.15625	13/32	.40625	21/32	.65625	29/32	.90625
3/16	.1875	7/16	.4375	11/16	.6875	15/16	.9375
7/32	.21875	15/32	.46875	23/32	.71875	31/32	.96875
1/4	.25	1/2	.5	3/4	.75		

UNLESS OTHERWISE SPECIFIED DIMENSIONS ARE IN INCHES TOLERANCES ARE:

FRACTIONS ANGLES
+/- 1/16" +/- 1deg

DIMENSIONS TO SHARP POINTS

SHEET NAME
BUMPER INSTALL

CURRENT CUSTOMER

WO#

SCALE 1:12

TITLE
17075 INSTALL ON 2009 MACK CXU

STOCK NUMBER

VENDOR NUMBER

WEIGHT - LB.

378.

DRAWN BY

GW

DRAWN DATE

5/25/2009

REV.

MODELLER

GW

DRAWING NUMBER

AA-20526

NUMBER OF SHEETS

1