

INSERT IN REAR TOW SOCKET AND TURN 90° TO LOCK
CRITICAL TYP (2)

DETAIL B
SCALE 1 : 4

B

1/2 - 13 UNC X 1 1/2 GRADE 8 CAPSCREW, 2 WASHERS AND GR. C STOVER NUT TYP (4) (SUPPLIED)

3/4 - 10 UNC X 3 1/2 GRADE 8 CAPSCREW AND WASHER TYP (2) (SUPPLIED)

END OF BRACKET INSTALLS TO **INSIDE** OF PLATE

SPACER

SEE BRACKET INSTALL SHEET FOR DETAILS

*****CHECK CLEARANCE TO STEERING ARM IN LEFT TURN AT LOCK AFTER INSTALL*****

M12 X 1.75 X 40MM CLASS 10.9 CAPSCREW & WASHER TYP (4) (NOT SUPPLIED) **INSTALL FIRST**

1/2 - 13 UNC X 1 1/2 GRADE 8 CAPSCREW, 2 WASHERS AND GR. C STOVER NUT TYP (10) (SUPPLIED)

OPEN AND CLOSE BUMPER AND HOOD CAREFULLY UNTIL FINAL FIT IS COMPLETE TO PREVENT DAMAGE TO TRUCK AND BUMPER

5/8 - 11 UNC X 2 GRADE 8 CAPSCREW, 2 WASHERS AND GR. C STOVER NUT TYP (4) (NOT SUPPLIED)

5/8 - 11 UNC X 3 GRADE 8 CAPSCREW, 2 WASHERS AND GR. C STOVER NUT TYP (2) (SUPPLIED)

MAGNUM TRAILER & EQUIPMENT INC.



PROCESS CODES

- | | |
|---------------------------|----------------------|
| A - MODIFY SURFACE FINISH | Q - PAINT OR COATING |
| B - BURN (FLAME) | R - ROLLED |
| C - CUT TO LENGTH | S - SHEAR |
| D - DRILL | T - TRIM |
| F - FORM | V - LAYOUT |
| H - HI DEF PLASMA | W - WATER CUT |
| K - CAST | X - EXTRUDE |
| L - LASER | Y - MODIFY |
| M - MACHINE | Z - HEAT TREAT |
| P - PUNCH | |

UNLESS OTHERWISE SPECIFIED DIMENSIONS ARE IN INCHES TOLERANCES ARE:

FRACTIONS ANGLES
+/- 1/16" +/- 1deg

DIMENSIONS TO SHARP POINTS

SHEET NAME

Sheet1

CURRENT CUSTOMER

WO#

SCALE

1:8

TITLE

17072 ON INTERNATIONAL LONESTAR

STOCK NUMBER

VENDOR NUMBER

WEIGHT - LB.

DRAWN BY

MK

DRAWN DATE

1/19/2009

REV.

D

MODELLER

GW

DRAWING NUMBER

AA-19988

NUMBER OF SHEETS

1

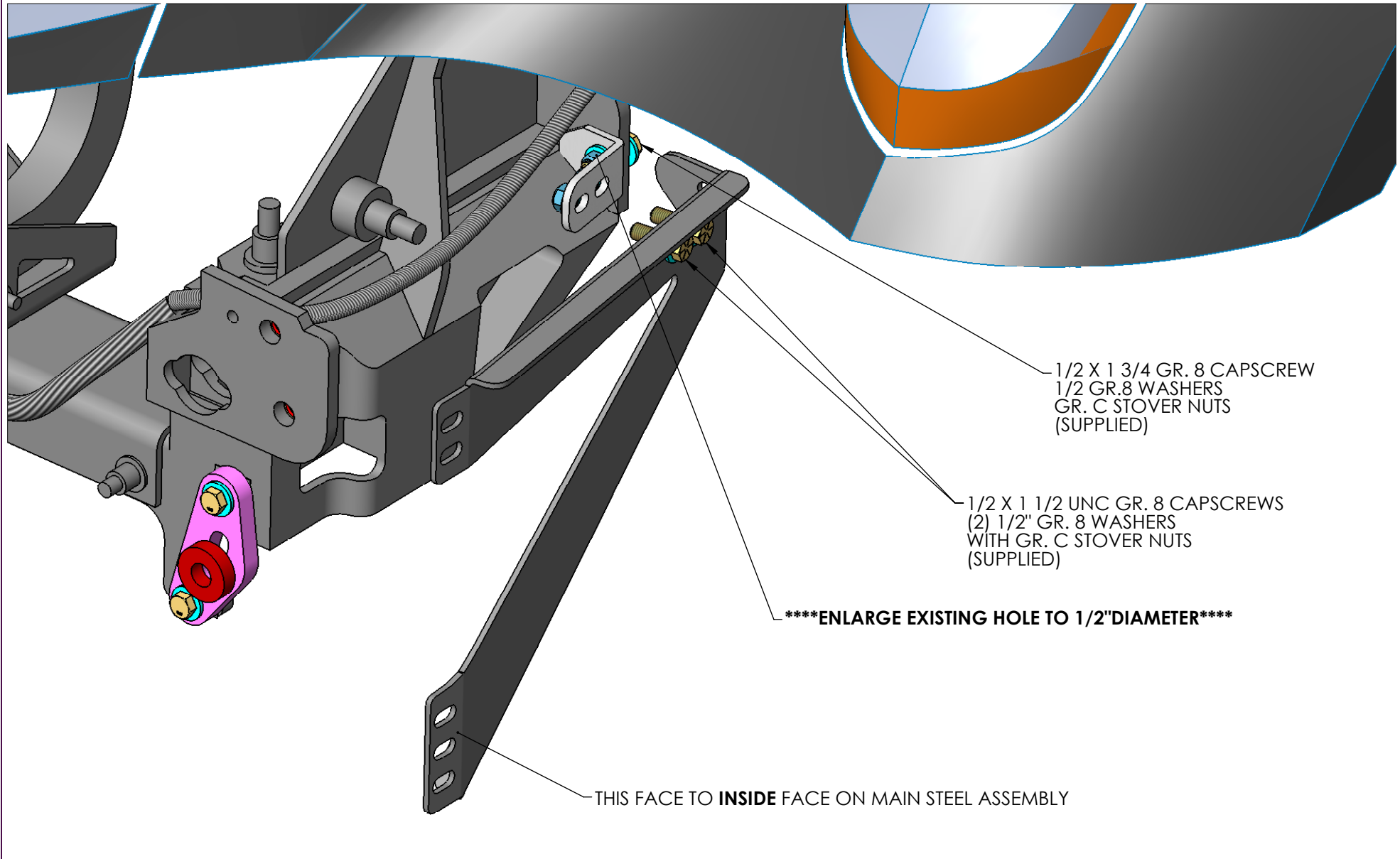

MAGNUM TRAILER & EQUIPMENT INC.



PROCESS CODES

- | | |
|---------------------------|----------------------|
| A - MODIFY SURFACE FINISH | Q - PAINT OR COATING |
| B - BURN (FLAME) | R - ROLLED |
| C - CUT TO LENGTH | S - SHEAR |
| D - DRILL | T - TRIM |
| F - FORM | V - LAYOUT |
| H - HI DEF PLASMA | W - WATER CUT |
| K - CAST | X - EXTRUDE |
| L - LASER | Y - MODIFY |
| M - MACHINE | Z - HEAT TREAT |
| P - PUNCH | |

UNLESS OTHERWISE SPECIFIED
DIMENSIONS ARE IN INCHES
TOLERANCES ARE:

FRACTIONS ANGLES
+/- 1/16" +/- 1deg

DIMENSIONS TO SHARP POINTS

SHEET NAME BRACKET INSTALL		TITLE 17072 ON INTERNATIONAL LONESTAR	
CURRENT CUSTOMER	STOCK NUMBER	VENDOR NUMBER	WEIGHT - LB.
WO#	DRAWN BY MK	DRAWN DATE 1/19/2009	REV. D
SCALE 1:8	MODELLER GW	DRAWING NUMBER AA-19988	NUMBER OF SHEETS 1

SLIDE LAMP DOWNWARD INTO POSITION AND BOLT THRU

SILICONE TOP OF BRACKET AND UP TO ARROW BOTH SIDES TYP (2)

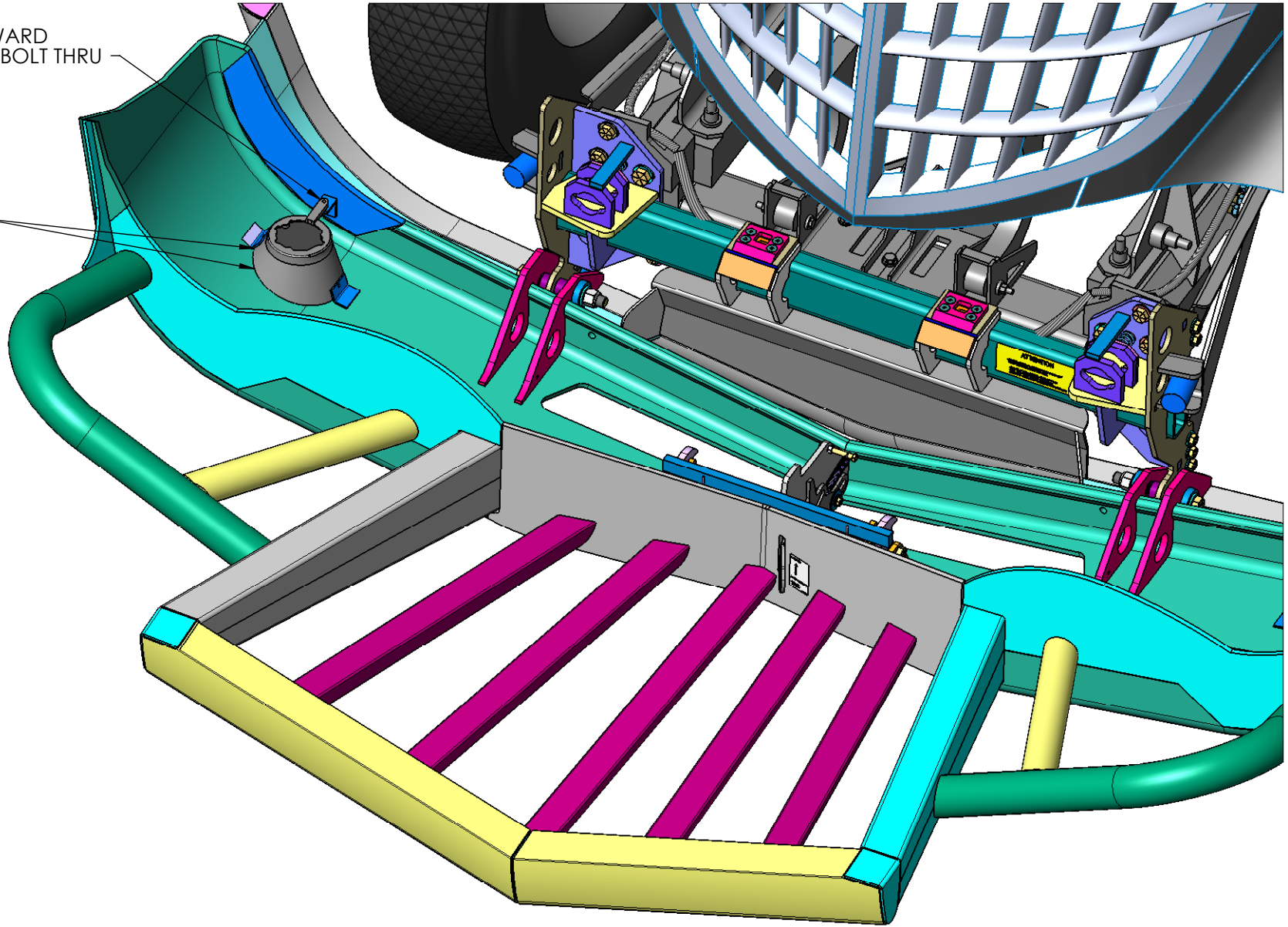

MAGNUM TRAILER & EQUIPMENT INC.



PROCESS CODES

- | | |
|---------------------------|----------------------|
| A - MODIFY SURFACE FINISH | Q - PAINT OR COATING |
| B - BURN (FLAME) | R - ROLLED |
| C - CUT TO LENGTH | S - SHEAR |
| D - DRILL | T - TRIM |
| F - FORM | V - LAYOUT |
| H - HI DEF PLASMA | W - WATER CUT |
| K - CAST | X - EXTRUDE |
| L - LASER | Y - MODIFY |
| M - MACHINE | Z - HEAT TREAT |
| P - PUNCH | |

UNLESS OTHERWISE SPECIFIED DIMENSIONS ARE IN INCHES TOLERANCES ARE:

FRACTIONS $\pm 1/16"$ ANGLES $\pm 1 \text{deg}$

DIMENSIONS TO SHARP POINTS

SHEET NAME
LIGHT INSTALL

CURRENT CUSTOMER

WO#

SCALE 1:10

TITLE
17072 ON INTERNATIONAL LONESTAR

STOCK NUMBER

DRAWN BY
MK

MODELLER
GW

VENDOR NUMBER

DRAWN DATE
1/19/2009

DRAWING NUMBER
AA-19988

WEIGHT - LB.

REV.
D

NUMBER OF SHEETS
1