

INSTALL TOWSTRAP ASSEMBLY (SUPPLIED) BEFORE INSTALLING BUMPER TO TRUCK

INSTALLER TO DRILL UPON ASSEMBLY

5/8" NC X 2" GR. 8 BOLT WITH WASHERS AND GR. C STOVER (NOT SHOWN) THRU FRONT X/M INSTALLER DRILL (2) PLACES (NOT SUPPLIED)

5/8" NF GR. 8 NUT AND WASHER (SUPPLIED) TYP (2) ADJUST STUD POSITION SO THAT STUD PROTRUDES THRU NUT 2 THREADS (SUPPLIED)

1/2" NC X 1 1/4" GR. 8 CAPSCREW WITH GR. 8 WASHER INTO EXISTING TAPPED HOLE IN X/M TYP (2) (NOT SUPPLIED)

1/2" NC X 2" GR. 8 CAPSCREW WITH GR 8 WASHER TYP (4) (NOT SUPPLIED)

1/2" NC GRADE C STOVER NUT WITH GR. 8 WASHER TYP (2) (NOT SUPPLIED)

SPACERS - SUPPLIED

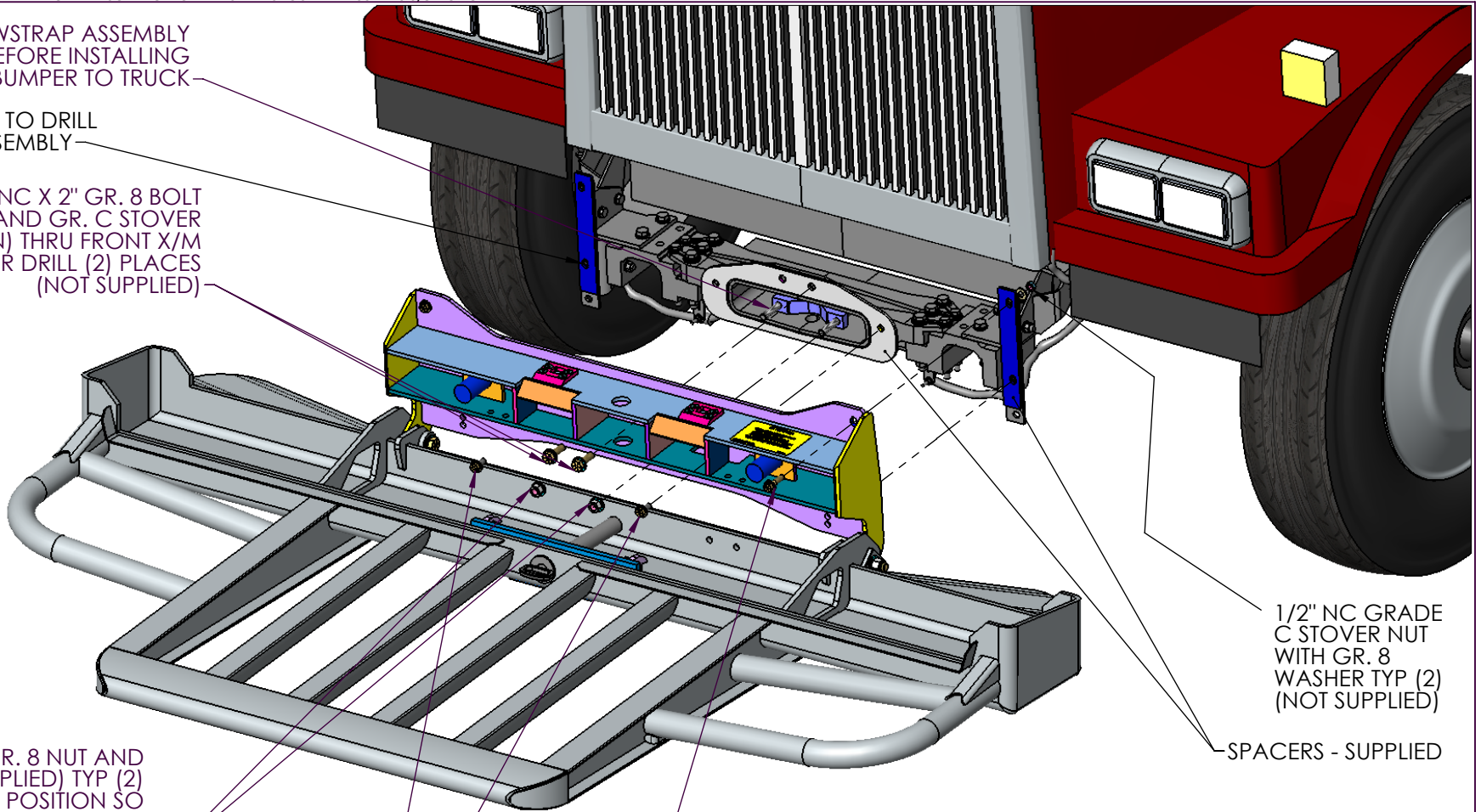

MAGNUM TRAILER & EQUIPMENT INC.



FRACTIONS CHART

1/32	.03125	9/32	.28125	17/32	.53125	25/32	.78125
1/16	.0625	5/16	.3125	9/16	.5625	13/16	.8125
3/32	.09375	11/32	.34375	19/32	.59375	27/32	.84375
1/8	.125	3/8	.375	5/8	.625	7/8	.875
5/32	.15625	13/32	.40625	21/32	.65625	29/32	.90625
3/16	.1875	7/16	.4375	11/16	.6875	15/16	.9375
7/32	.21875	15/32	.46875	23/32	.71875	31/32	.96875
1/4	.25	1/2	.5	3/4	.75		

UNLESS OTHERWISE SPECIFIED DIMENSIONS ARE IN INCHES TOLERANCES ARE:

FRACTIONS ANGLES
+/- 1/16" +/- 1deg

DIMENSIONS TO SHARP POINTS

A	ADDED SHIPPING HOLE TO STEEL MOUNT ASS'Y	10/22/2012	KW
REV.	CHANGES OR ADDITIONS	DATE	REV. BY

SHEET NAME Sheet1		TITLE 17069 BUMPER ON 2008 WESTERN STAR 4900 FA	
CURRENT CUSTOMER	STOCK NUMBER	VENDOR NUMBER	WEIGHT - LB. 1287.
WO#	DRAWN BY GW	DRAWN DATE 10/20/2008	REV. A
SCALE 1:14	MODELLER GW	DRAWING NUMBER AA-19828	NUMBER OF SHEETS 1