

USE FASTENER GRADES SPECIFIED

MAGNUM TRAILER & EQUIPMENT INC.



PROCESS CODES

- | | |
|---------------------------|----------------------|
| A - MODIFY SURFACE FINISH | Q - PAINT OR COATING |
| B - BURN (FLAME) | R - ROLLED |
| C - CUT TO LENGTH | S - SHEAR |
| D - DRILL | T - TRIM |
| F - FORM | V - LAYOUT |
| H - HI DEF PLASMA | W - WATER CUT |
| K - CAST | X - EXTRUDE |
| L - LASER | Y - MODIFY |
| M - MACHINE | Z - HEAT TREAT |
| P - PUNCH | |

UNLESS OTHERWISE SPECIFIED
DIMENSIONS ARE IN INCHES
TOLERANCES ARE:

FRACTIONS ANGLES
+/- 1/16" +/- 1deg

DIMENSIONS TO SHARP POINTS

SHEET NAME INSTALL		TITLE KW17050 BUMPER ON 2004 KW W900 L	
CURRENT CUSTOMER	STOCK NUMBER	VENDOR NUMBER	WEIGHT - LB. 845.
WO#	DRAWN BY JD	DRAWING DATE 12/21/2007	REV. A
SCALE 1:12	MODELLER GW	DRAWING NUMBER AA-18655	NUMBER OF SHEETS

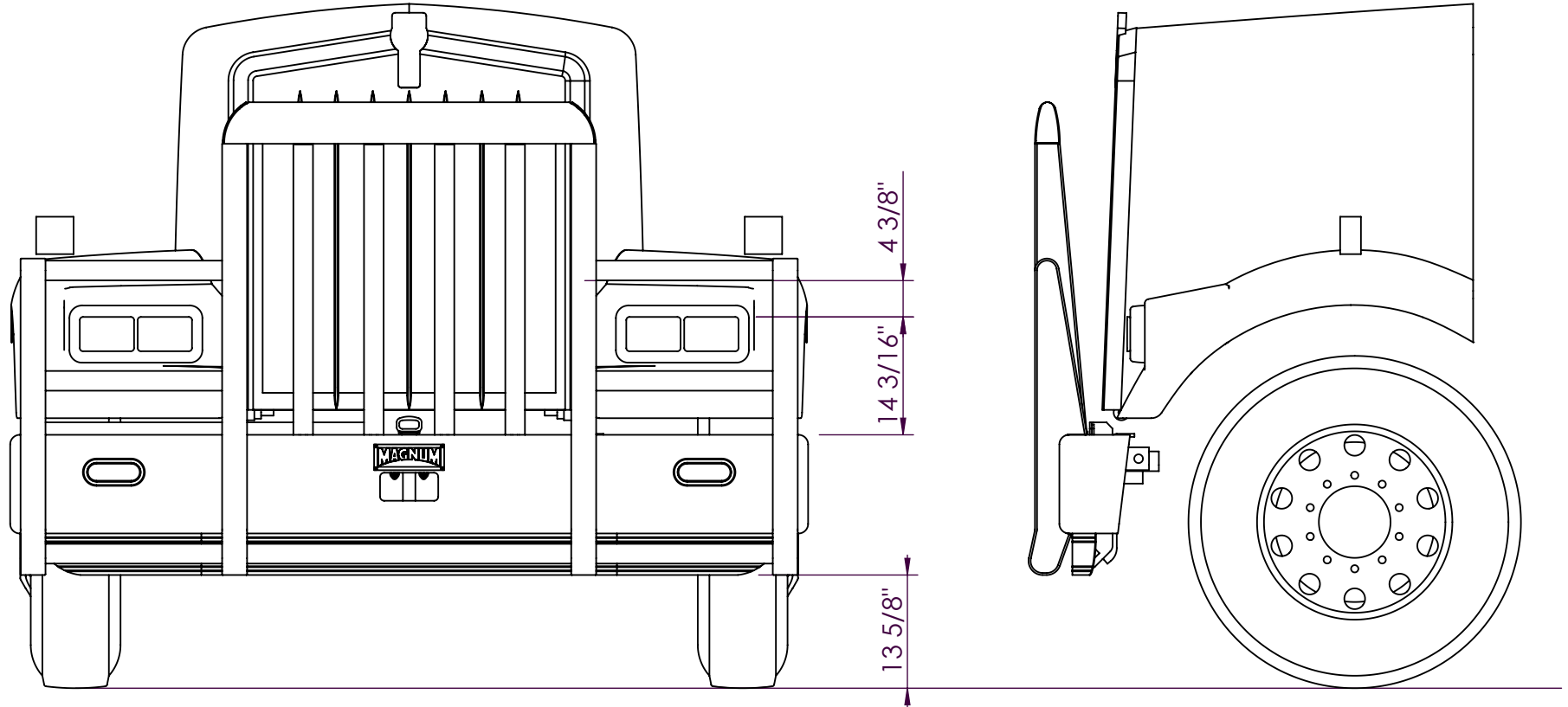

MAGNUM TRAILER & EQUIPMENT INC.



PROCESS CODES

- | | |
|---------------------------|----------------------|
| A - MODIFY SURFACE FINISH | Q - PAINT OR COATING |
| B - BURN (FLAME) | R - ROLLED |
| C - CUT TO LENGTH | S - SHEAR |
| D - DRILL | T - TRIM |
| F - FORM | V - LAYOUT |
| H - HI DEF PLASMA | W - WATER CUT |
| K - CAST | X - EXTRUDE |
| L - LASER | Y - MODIFY |
| M - MACHINE | Z - HEAT TREAT |
| P - PUNCH | |

UNLESS OTHERWISE SPECIFIED
DIMENSIONS ARE IN INCHES
TOLERANCES ARE:

FRACTIONS ANGLES
+/- 1/16" +/- 1deg

DIMENSIONS TO SHARP POINTS

SHEET NAME
SALES DIMENSIONS

CURRENT CUSTOMER

WO#

SCALE 1:20

TITLE
KW17050 BUMPER ON 2004 KW W900 L

STOCK NUMBER

VENDOR NUMBER

WEIGHT - LB.

845.

DRAWN BY
JD

DRAWN DATE

12/21/2007

REV.
A

MODELLER
GW

DRAWING NUMBER

AA-18655

NUMBER OF SHEETS