

**USE FASTENER GRADES SPECIFIED**

<b>MAGNUM TRAILER &amp; EQUIPMENT INC.</b> 	<b>PROCESS CODES</b> A - MODIFY SURFACE FINISH B - BURN (FLAME) C - CUT TO LENGTH D - DRILL F - FORM H - HI DEF PLASMA K - CAST L - LASER M - MACHINE P - PUNCH Q - PAINT OR COATING R - ROLLED S - SHEAR T - TRIM V - LAYOUT W - WATER CUT X - EXTRUDE Y - MODIFY Z - HEAT TREAT		UNLESS OTHERWISE SPECIFIED DIMENSIONS ARE IN INCHES TOLERANCES ARE: FRACTIONS $\pm 1/16"$ ANGLES $\pm 1\text{deg}$		SHEET NAME <b>INSTALL</b>		TITLE <b>KW17004 BUMPER ON 2004 KW W900 L</b>	
			DIMENSIONS TO SHARP POINTS		CURRENT CUSTOMER		STOCK NUMBER	
					DRAWN BY GW		DRAWN DATE 11/25/2004	
					SCALE 1:12		MODELLER GW	
				WEIGHT - LB. 808.		REV. C		
				DRAWING NUMBER <b>AA-11476</b>		NUMBER OF SHEETS		

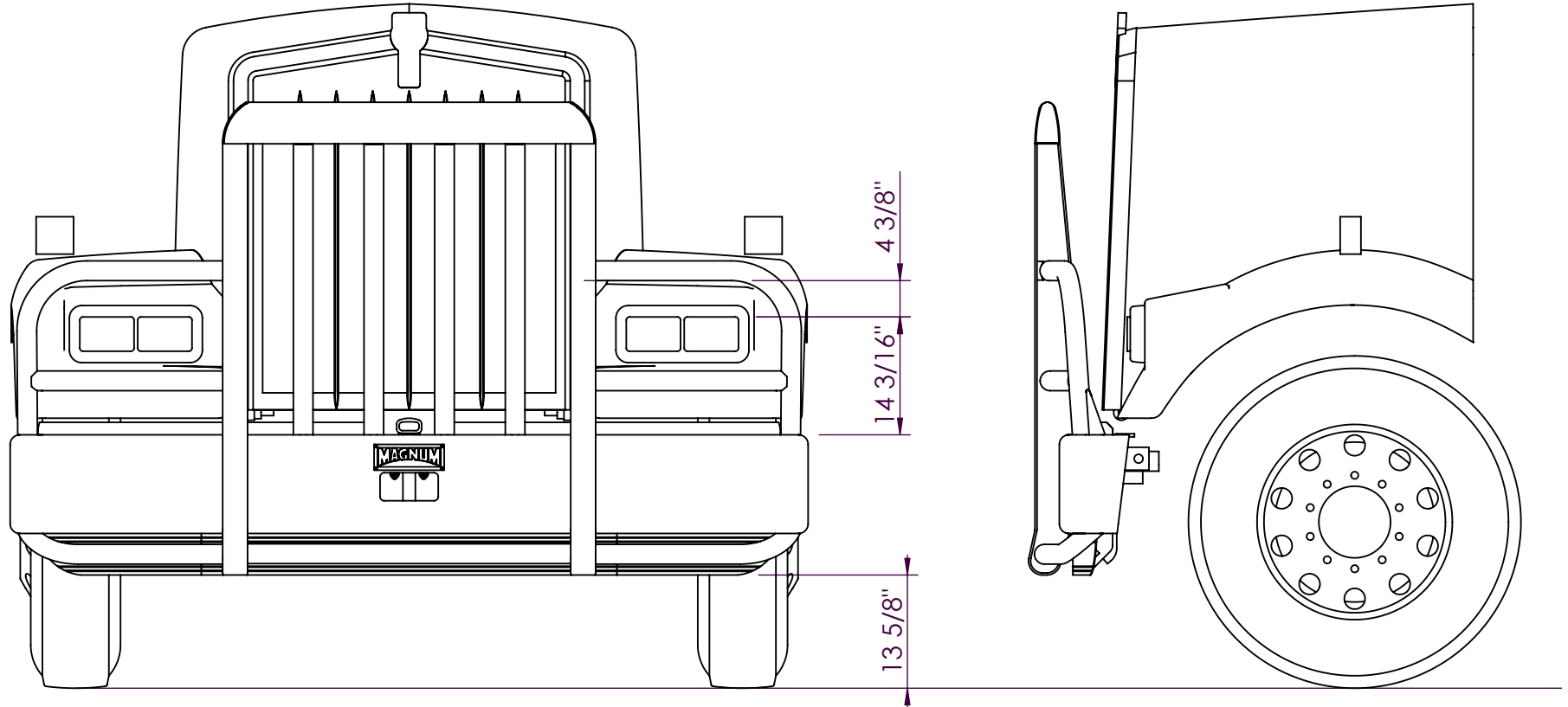

**MAGNUM TRAILER & EQUIPMENT INC.**



**PROCESS CODES**

- |                           |                      |
|---------------------------|----------------------|
| A - MODIFY SURFACE FINISH | Q - PAINT OR COATING |
| B - BURN (FLAME)          | R - ROLLED           |
| C - CUT TO LENGTH         | S - SHEAR            |
| D - DRILL                 | T - TRIM             |
| F - FORM                  | V - LAYOUT           |
| H - HI DEF PLASMA         | W - WATER CUT        |
| K - CAST                  | X - EXTRUDE          |
| L - LASER                 | Y - MODIFY           |
| M - MACHINE               | Z - HEAT TREAT       |
| P - PUNCH                 |                      |

UNLESS OTHERWISE SPECIFIED  
DIMENSIONS ARE IN INCHES  
TOLERANCES ARE:

FRACTIONS  $\pm 1/16"$  ANGLES  $\pm 1$ deg

DIMENSIONS TO SHARP POINTS

SHEET NAME  
**SALES DIMENSIONS**

CURRENT CUSTOMER

**WO#**

SCALE 1:20

TITLE  
**KW17004 BUMPER ON 2004 KW W900 L**

STOCK NUMBER

VENDOR NUMBER

WEIGHT - LB.

808.

DRAWN BY  
GW

DRAWN DATE  
11/25/2004

REV.  
**C**

MODELLER  
GW

DRAWING NUMBER  
**AA-11476**

NUMBER OF SHEETS